

# DYNAMICS OF TRANSCENDENTAL MEROMORPHIC FUNCTIONS

**P. Domínguez**

Imperial College of Science, Technology and Medicine, Department of Mathematics  
London SW7 2BZ, United Kingdom; p.dominguez@fcfm.bvap.mx

**Abstract.** The paper examines some properties of the dynamics of entire functions which extend to general meromorphic functions and also some properties which do not. For a transcendental meromorphic function  $f(z)$  whose Fatou set  $F(f)$  has a component of connectivity at least three, it is shown that singleton components are dense in the Julia set  $J(f)$ . Some problems remain open if all components are simply or doubly connected.

Let  $I(f)$  denote the set of points whose forward orbits tend to  $\infty$  but never land at  $\infty$ . For a transcendental meromorphic function  $f(z)$  we have  $J(f) = \partial I(f)$ ,  $I(f) \cap J(f) \neq \emptyset$ . However in contrast to the entire case, the components of  $\overline{I(f)}$  need not be unbounded, even if  $f(z)$  has only one pole.

If  $f(z)$  has finitely many poles then, as in the entire case,  $F(f)$  has at most one completely invariant component.

## 1. Introduction

Let  $f(z): \mathbf{C} \rightarrow \widehat{\mathbf{C}}$  denote a meromorphic function,  $f^n$ ,  $n \in \mathbf{N}$ , the  $n$ th iterate of  $f(z)$ , and  $f^{-n}$  the set of inverse functions of  $f^n$ .

Let  $A$  be the set of poles of  $f(z)$ ,  $B = \bigcup_{n=1}^{\infty} f^{-n}(A)$  the set of preimages of  $\infty$ , and  $B'$  the derived set of  $B$ .

The Fatou set  $F(f)$  is defined to be the set of those points  $z \in \widehat{\mathbf{C}}$  such that the sequence  $(f^n)_{n \in \mathbf{N}}$  is well defined, is meromorphic, and forms a normal family in some neighbourhood of  $z$ . The complement  $J(f)$  of  $F(f)$  is called the Julia set of  $f(z)$ .

We define  $E(f)$  to be the set of exceptional values of  $f(z)$ , that is, the points whose inverse orbit  $O^-(z) = \{w : f^n(w) = z \text{ for some } n \in \mathbf{N}\}$  is finite. There can be at most two such points and if  $\infty \in E(f)$  then either  $f(z)$  is entire or has a single pole  $\alpha$  which is a Picard value of  $f(z)$ , so that

$$(1) \quad f(z) = \alpha + (z - \alpha)^{-k} e^{g(z)},$$

for some  $k \in \mathbf{N}$  and some entire function  $g(z)$ . The meromorphic functions thus fall into four disjoint classes.

- (i) The rational functions (where we assume the degree to be at least two).
- (ii) The class **E** of transcendental entire functions.
- (iii) The class **P** of transcendental functions of the type (1), self maps of the punctured plane which have a meromorphic extension to  $\mathbf{C}$ .
- (iv) **M**, the class called general meromorphic functions in [11], of transcendental meromorphic functions, for which  $\infty \notin E(f)$ .

The iteration of the class (i) and (ii) is sufficiently well known. The class **P** has been studied in [7], [15], [17], [23]–[25], [32]–[38], [41] and **M** in [9], [10], [11]. See [14] for a survey of the main results. For the first three classes the iterates are automatically defined in the plane or punctured plane and the study of the normality of  $\{f^n\}$  is the main feature. For  $f(z) \in \mathbf{M}$  the set  $B$ , defined above, is infinite and it is shown in [9] that  $J(f) = \overline{B} = B'$ .

Many properties of  $J(f)$  and  $F(f)$  are much the same for **M** as for the other classes but different proofs are needed and some discrepancies arise. We recall (see e.g. [14]) that for  $f(z)$  in any of the four classes:

1.  $F(f)$  is open and completely invariant under  $f(z)$ , that is,  $z \in F(f)$  if and only if  $f(z) \in F(f)$ .
2. For  $z_0 \notin E(f)$ ,  $J(f) \subset \overline{O^-(z_0)}$ .
3. Repelling periodic points are dense in  $J(f)$ .
4. If  $U$  is a periodic component of  $F(f)$  of period  $p$ , that is if  $f^p(U) \subset U$ , there are the following possible cases:
  - $U$  contains an attracting periodic point  $z_0$  of period  $p$ . Then  $f^{np}(z) \rightarrow z_0$  for  $z \in U$  as  $n \rightarrow \infty$ , and  $U$  is called the immediate attractive basin of  $z_0$ .
  - $\partial U$  contains a periodic point  $z_0$  of period  $p$  and  $f^{np}(z) \rightarrow z_0$  for  $z \in U$  as  $n \rightarrow \infty$ . Then  $(f^p)'(z_0) = 1$  if  $z_0 \in \mathbf{C}$ . (For  $z_0 = \infty$  we have  $(g^p)'(0) = 1$  where  $g(z) = 1/f(1/z)$ .) In this case,  $U$  is called a Leau domain.
  - There exists an analytic homeomorphism  $\psi: U \rightarrow D$  where  $D$  is the unit disc such that  $\psi(f^p(\psi^{-1}(z))) = e^{2\pi i \alpha} z$  for some  $\alpha \in \mathbf{R} \setminus \mathbf{Q}$ . In this case,  $U$  is called a Siegel disc.
  - There exists an analytic homeomorphism  $\psi: U \rightarrow A$  where  $A$  is an annulus  $A = \{z : 1 < |z| < r\}$ ,  $r > 1$ , such that  $\psi(f^p(\psi^{-1}(z))) = e^{2\pi i \alpha} z$  for some  $\alpha \in \mathbf{R} \setminus \mathbf{Q}$ . In this case,  $U$  is called a Herman ring.
  - There exists  $z_0 \in \partial U$  such that  $f^{np}(z) \rightarrow z_0$ , for  $z \in U$  as  $n \rightarrow \infty$ , but  $f^p(z_0)$  is not defined. In this case,  $U$  is called a Baker domain.
5. If  $p = 1$  in 4, that is if  $U$  is an invariant component of  $F(f)$ , then  $U$  has connectivity 1, 2, or  $\infty$ . If the connectivity is two, then  $U$  is a Herman ring.

The purpose of this paper is to examine whether some properties of the sets  $J(f)$  or  $F(f)$ , which hold for transcendental entire functions, extend to transcendental meromorphic functions or perhaps at least to transcendental meromorphic

functions with finitely many poles.

It is known that the Fatou set  $F(g)$  of a transcendental entire function  $g(z)$  may have a multiply-connected component  $U$  [1], that any such component is bounded [3], and that  $g^n \rightarrow \infty$  in  $U$  so that each  $g^n(U)$  belongs to a different component of  $F(g)$ . It is a corollary that  $J(g)$  is not totally disconnected but a recent result [20] shows that if  $U$  is multiply connected, then singleton components are everywhere dense in  $J(g)$ .

The existence of singleton components of  $J(f)$  for transcendental meromorphic functions follows from the following general result.

**Theorem A.** *Suppose that  $f(z)$  is a transcendental meromorphic function and that  $F(f)$  has a component  $H$  of connectivity at least three. Then singleton components are dense in  $J(f)$ .*

We note that in [10] there are examples of functions in  $\mathbf{M}$  with Fatou components of any prescribed connectivity.

If  $R$  is a doubly-connected component of  $F(f)$ , then its complement consists of two components, one bounded and the other unbounded. The methods used to prove Theorem A also give Theorem B.

**Theorem B.** *Suppose that  $f(z)$  is a transcendental meromorphic function and that  $F(f)$  has three doubly-connected components  $U_i$  such that either,*

- (a) *each component lies in the unbounded component of the complement of the other two or*
- (b) *two of the components  $U_1, U_2$  lie in the bounded component of  $U_3^c$  but  $U_1$  lies in the unbounded component of  $U_2^c$  and  $U_2$  lies in the unbounded component of  $U_1^c$ .*

*Then singleton components are dense in  $J(f)$ .*

The preceding results show that if for the transcendental meromorphic function  $f(z)$  the Julia set has no singleton components, then any multiply-connected component of  $F(f)$  has connectivity two and moreover, the distribution of these doubly-connected components is subject to severe restrictions. On the other hand we have not been able to show that such components cannot occur. For functions  $f(z)$  of class  $\mathbf{P}$  it is known [7] that  $F(f)$  can have at most one multiply-connected component and the connectivity of such component is 2. Thus  $J(f)$  has no singleton components.

W. Bergweiler in [14, p. 164] mentions the problem of whether a meromorphic function  $f(z)$  in the special class  $\mathbf{P}$  can have a Herman ring. This would necessarily be invariant. The question is answered by the following theorem.

**Theorem C.** *If  $f(z) \in \mathbf{P}$ , then  $f(z)$  has no Herman ring.*

If we drop the requirement that  $f(z)$  is transcendental the rational function  $R(z) = z^2 + \lambda/z^3$ ,  $\lambda > 0$ , has infinitely many doubly-connected Fatou components,

while  $J(R)$  is a Cantor set of circles and in particular has no singleton components, see [13, p. 266] for the details.

**Theorem D.** *Let  $f(z)$  be a transcendental meromorphic function and suppose that  $F(f)$  has multiply-connected components  $A_i$ ,  $i \in \mathbf{N}$ , all different, such that each  $A_i$  separates 0, and  $\infty$  and  $f(A_i) \subset A_{i+1}$  for  $i \in \mathbf{N}$ . Then  $J(f)$  has a dense set of singleton components.*

There are examples of  $f(z) \in \mathbf{E}$  which satisfy the assumptions of Theorem D and in this case  $A_i \rightarrow \infty$  [4], [5]. It is not easy to determine the connectivity of  $A_i$  although examples are known [6] where this is infinite. It seems to be an open problem as to where the connectivity of  $A_i$  can be 2 for  $f(z) \in \mathbf{E}$ . Similar constructions would give examples of functions in  $\mathbf{M}$  with a finite number of poles and  $A_i$  which tend to  $\infty$ . More interesting examples can be given by other methods as shown by Theorem E.

**Theorem E.** *There is a transcendental meromorphic function such that  $F(f)$  has a sequence of multiply-connected components  $A_i$ ,  $i \in \mathbf{N}$ , all different, such that each  $A_i$  separates 0 and  $\infty$  and  $f(A_i) \subset A_{i+1}$ ,  $i \in \mathbf{N}$ . Moreover  $A_{2i} \rightarrow \infty$  as  $i \rightarrow \infty$  and  $A_{2i+1} \rightarrow 0$  as  $i \rightarrow \infty$ .*

It will follow from the later Theorem G that any function which satisfies the assumption of Theorem E has infinitely many poles.

**Functions with finitely many poles.** We shall examine whether a number of results about the dynamics of transcendental entire functions extend to meromorphic functions with finitely many poles. A useful tool here is a theorem of H. Bohr (Theorem 5.1) which was used already in dynamics by Pólya [40] to estimate the growth of composed functions such as iterates. We make a slight extension of the result in Theorem 5.2. From it we shall deduce the following

**Theorem F.** *If  $f(z)$  is a transcendental meromorphic function with finitely many poles, then there is some  $S > 0$  such that no invariant component  $G$  of  $F(f)$  can contain a curve  $\gamma$  which lies in  $\{z : |z| > S\}$  and satisfies  $n(\gamma, 0) \neq 0$ .*

**Corollary.** *If  $f$  is a transcendental meromorphic function with finitely many poles, then  $J(f)$  cannot be totally disconnected.*

The result is known for  $f(z) \in \mathbf{E}$  [3] but is untrue for meromorphic functions without restriction to finitely many poles. For example, the function  $f(z) = \lambda \tan z$ ,  $0 < \lambda < 1$ , has a Julia set which is a Cantor subset of the real line, see [10] and [19]. For  $f(z) \in \mathbf{E}$  any unbounded invariant component is simply connected. This is no longer true for functions with even one pole. We show in Section 9 that for  $\varepsilon = 10^{-2}$ ,  $f(z) = z + 2 + e^z + \varepsilon(z - (1 + i\pi))^{-1}$  has a multiply-connected invariant component in which  $f^n(z) \rightarrow \infty$ .

**Orbits which tend to  $\infty$ .** For  $f(z) \in \mathbf{E}$  Eremenko [21] studied the set

$$I(f) = \{z \in \mathbf{C} : f^n(z) \rightarrow \infty \text{ as } n \rightarrow \infty\}.$$

He proved that for  $f(z) \in \mathbf{E}$  we have (a)  $I(f) \neq \emptyset$ , (b)  $J(f) = \partial I(f)$ , (c)  $I(f) \cap J(f) \neq \emptyset$ , and (d) the closure  $\overline{I(f)}$  of  $I(f)$  has no bounded components. It remains open as to whether  $I(f)$  itself may have bounded components. Fatou [27] had already noted that in the examples studied by him,  $I(f)$  contains unbounded analytic curves and asked whether this was a general phenomenon.

For meromorphic functions  $f(z)$  we generalise Eremenko's definition by writing

$$I(f) = \{z \in \mathbf{C} : f^n(z) \rightarrow \infty \text{ as } n \rightarrow \infty \text{ and } f^n(z) \neq \infty\}.$$

We show in Section 6 that for transcendental meromorphic functions  $I(f)$  has the properties (a), (b), and (c) listed above but (d) does not hold in general, even for functions with finitely many poles. These results form the following five theorems.

**Theorem G.** *For a transcendental meromorphic function  $f(z)$  with only finitely many poles the set  $I(f)$  is not empty. Indeed for any curve  $\gamma$  with  $n(\gamma, 0) \neq 0$  and such that  $d(0, \gamma)$  is sufficiently large we have  $I(f) \cap \gamma \neq \emptyset$ .*

**Theorem H.** *For a transcendental meromorphic function  $f(z)$  with infinitely many poles the set  $I(f)$  is not-empty. Indeed in any neighbourhood of a pole there are points of  $I(f)$ .*

**Theorem I.** *If  $f(z)$  is a transcendental meromorphic function, then  $J(f) = \partial I(f)$ .*

**Theorem J.** *If  $f(z)$  is a transcendental meromorphic function, then  $I(f) \cap J(f) \neq \emptyset$ .*

Theorems G and J follow from the same argument as Theorem F, based on our extension of Bohr's theorem. This gives an alternative to Eremenko's proof in the special case of entire functions. His proof was based on Wiman–Valiron theory.

The assertion of Theorem G is not in general true for meromorphic functions with infinitely many poles. For example, if  $f(z) = \lambda \tan z$ ,  $0 < \lambda < 1$ , then  $\overline{I(f)} \subset J(f)$ , and  $J(f)$  is a real Cantor set which fails to meet  $\gamma = C(0, r)$  for many arbitrarily large values of  $r$ . However, we shall have  $I(f) \neq \emptyset$ . Further (d) fails for this choice of  $f(z)$ , since every component of  $\overline{I(f)}$  is bounded. The example  $f(z) = \lambda \sin z - \varepsilon/(z - \pi)$ ,  $\varepsilon > 0$ ,  $0 < \lambda < 1$ , considered in Section 9 shows that if  $g(z)$  has even one pole, then  $\overline{I(g)}$  may have bounded components.

**Completely invariant components.** For transcendental functions it has been known since the early work of Fatou and Julia that  $F(f)$  can have at most two completely invariant components. In [8] it was shown that if  $f(z) \in \mathbf{E}$ , then there is at most one completely invariant component of  $F(f)$ . In Section 7 we show that this last result extends to transcendental meromorphic functions with finitely many poles.

**Theorem K.** *Let  $f(z)$  be a meromorphic function with at most finitely many poles. Then there is at most one completely invariant Fatou domain.*

The theorem fails for functions with infinitely many poles. For example if  $f(z) = \lambda \tan z$ ,  $\lambda > 1$ , then  $F(f)$  has two completely invariant components namely the upper and lower half-plane (each of which contains an attracting fixed point). It is an open problem for general transcendental meromorphic functions as to whether the Fatou set can have more than two completely invariant components. However for a transcendental function whose inverse is singular at only finitely many points the maximum number of completely invariant Fatou components is two [11].

**Functions with one pole.** The final section contains two examples. Recall that for  $f(z) \in \mathbf{E}$  any multiply-connected component  $G$  of  $F(f)$  is bounded with  $f^n \rightarrow \infty$  in  $G$ . This is no longer true for meromorphic functions with even one pole.

We show in Example 1 that for  $\varepsilon = 10^{-2}$  and  $a = 1 + i\pi$  the function  $f(z) = z + 2 + e^z + \varepsilon(z - a)^{-1}$  has a multiply-connected invariant component in which  $f^n(z) \rightarrow \infty$ .

In a similar way we show that for  $0 < \lambda < 1$  and for sufficiently small positive  $\varepsilon$  the function  $f(z) = \lambda \sin z - \varepsilon/(z - \pi)$  has a single completely invariant Fatou component. This is unbounded, multiply connected and the iterates  $f^n$  converge to a finite limit (an attracting fixed point) in  $F(f)$ . Singleton components of  $J(f)$  are dense in  $J(f)$ , which also contains unbounded continua.

We precede the examples by stating some results about the relation between the orbits of singular points of  $f^{-1}$  and the possible limit functions of iterates. These are used in the discussion of Example 2.

The author wishes to thank Professor I.N. Baker for many helpful suggestions, CONACyT (Consejo Nacional de Ciencia y Tecnología) and Universidad Autónoma de Puebla for their financial support.

## 2. Proof of Theorem A

In this section our aim is to prove Theorem A. We shall start this section by giving the following lemma.

**Lemma 1.** *If  $D$  is a domain in  $\widehat{\mathbf{C}}$  whose complement contains at least  $p$  components  $H_1, \dots, H_p$ , then there are  $p$  disjoint simple polygons  $\gamma_i$ ,  $0 \leq i \leq p$ , in  $D$  such that  $\gamma_i$  separates  $H_i$  from the remaining  $H_j$ ,  $j \neq i$ . Thus there is a component  $D_i$  of the complement of  $\gamma_i$  such that  $H_i \subset D_i$  and  $\overline{D}_i \cap \overline{D}_j = \emptyset$  for  $j \neq i$ .*

A proof may be obtained from results in [39]. Firstly there is a partition of the complement of  $D$  into  $p$  disjoint closed sets  $F_i$ , such that  $H_i \subset F_i$ ,  $1 \leq i \leq p$ . The method of Theorem 3.1 and Theorem 3.2 in Chapter VI of [39] gives a construction of a simple polygon  $\gamma_i$ , uniformly as close as we wish to a subset of  $F_i$  which satisfies the requirements of the lemma.

In order to prove Theorem A we require a result from Ahlfors' theory of covering surfaces. If a function  $g(z)$  is meromorphic in  $\mathbf{C}$  and  $D$  is a simply-connected domain in  $\widehat{\mathbf{C}}$ , whose boundary is a sectionally analytic Jordan curve  $\gamma$ , then an *island* (with respect to  $g(z)$ ) over  $D$  is a bounded component  $G$  of  $g^{-1}(D)$  so that  $g(G) = D$  and the map  $g: G \rightarrow D$  is a finite branched cover. Thus we have  $g(\partial G) = \gamma$ .

The following result is given as a corollary of Theorem VI.8 in [42]. It also follows from [30, Theorem 5.5].

**Lemma 2.** *If  $g(z)$  is a transcendental and meromorphic function in  $\mathbf{C}$ , then given any three simply-connected domains  $D_i$ ,  $1 \leq i \leq 3$ , with sectionally analytic boundaries, such that  $\overline{D}_i$  are mutually disjoint, there is at least one value of  $i$  such that  $g(z)$  has infinitely many simply-connected islands over  $D_i$ .*

**Proof of Theorem A.** Since the theorem is known for  $f(z) \in \mathbf{E}$  and since for  $f(z) \in \mathbf{P}$  there are no components of  $F(f)$  whose connectivity is greater than or equal to three, we can suppose that  $f(z) \in \mathbf{M}$  and that  $F(f)$  has a component  $D$  whose connectivity is at least three. Thus  $D^c$  has at least three components  $H_1, H_2, H_3$ . It follows from Lemma 1 that there are simple polygons  $\gamma_i$  in  $D$ ,  $1 \leq i \leq 3$ , and (simply-connected) complementary domains  $D_i$  of  $\gamma_i$  such that  $\overline{D}_i \cap \overline{D}_j = \emptyset$ ,  $j \neq i$ , and each  $D_i$  contains points of the Julia set.

Now pick any point  $\xi_1$  in the Julia set and any open neighbourhood  $V_1$  which contains  $\xi_1$ . Then there is some  $k \in \mathbf{N}$  such that  $f^k$  has a pole  $\beta$  in  $V_1$ .

There is a neighbourhood  $U$  of  $\beta$ ,  $\overline{U} \subset V_1$  which is mapped by  $f^k$  locally univalently (except perhaps at  $\beta$ ) onto a neighbourhood  $N$  of  $\infty$ .

It follows from Lemma 2 that  $f(z)$  has a simply-connected island  $G \subset N \cap \mathbf{C}$ , which lies over one of the  $D_i$ , say  $D_1$ . The branches of  $(f^k)^{-1}$  which take values in  $U$  for  $z \in G$  are each univalent in  $G$ . We take one such branch, say  $h$ , which maps  $G$  univalently onto the simply-connected domain  $V_2 \subset U \setminus \{\beta\}$ . Then  $f^{k+1}$  maps  $V_2$  onto  $D_1$  and since  $D_1$  meets  $J(f)$  it follows that  $V_2$  contains a point  $\xi_2$  of  $J(f)$ . From  $f^{k+1}(\partial V_2) = \gamma_1$  it follows that  $\partial V_2 \subset F(f)$ .

We may now replace  $V_1$  by  $V_2$ ,  $\xi_1$  by  $\xi_2$  and deduce that  $V_2$  contains an arbitrarily small simply-connected neighbourhood  $V_3$  such that  $\overline{V}_3 \subset V_2$ ,  $\partial V_3 \subset$

$F(f)$ , and  $\xi_3 \in V_3 \cap J(f) \neq \emptyset$ . By continuing inductively we obtain a sequence of nested simply-connected domains  $V_n$ , each of which contains a point  $\xi_n \in J(f)$ . The sets  $\overline{V}_n$  may be assumed to shrink to a single point  $\xi$ . Then  $\xi = \lim \xi_n \in J(f)$ . Further  $\partial V_n$  is constructed to be in  $F(f)$ , and so  $\xi$  is a singleton component of  $J(f)$ .

As an application of the preceding theorem we note that for any meromorphic function  $f(z)$  with a completely invariant multiply-connected component  $G$  of  $F(f)$ , the connectivity of  $G$  is infinite, by item 5 of the introduction, and hence  $J(f)$  has dense singleton components.

Further examples are given by the meromorphic functions constructed in [10] which have wandering Fatou components of arbitrary finite connectivity.

### 3. Proofs of Theorems B and C

**Proof of Theorem B.** We may suppose that  $f(z) \in \mathbf{M}$  since  $f(z) \in \mathbf{P}$  can have at most one doubly-connected Fatou component.

Let  $\gamma_i$ ,  $1 \leq i \leq 3$ , be sectionally analytic curves such that  $\gamma_i \subset U_i \subset F(f)$  and  $\gamma_i$  cannot be deformed to a point in  $U_i$ .

In case (a) we take  $D_i$  to be the interior of  $\gamma_i$ ,  $1 \leq i \leq 3$ , that is, the bounded component of  $\gamma_i^c$ . Now  $\gamma_1 \subset F(f)$  is separated by the boundary of the unbounded component of  $U_1^c$  from  $\gamma_2$  and  $\gamma_3$ . Hence  $\overline{D}_1, \overline{D}_2, \overline{D}_3$  are disjoint and each  $D_i$  contains points of  $J(f)$ . The proof now proceeds precisely as for Theorem A but using this interpretation of  $D_i$ .

In case (b) we take  $D_1$  and  $D_2$  as in case (a) but take  $D_3$  to be the exterior of  $\gamma_3$ . See Figure 1.

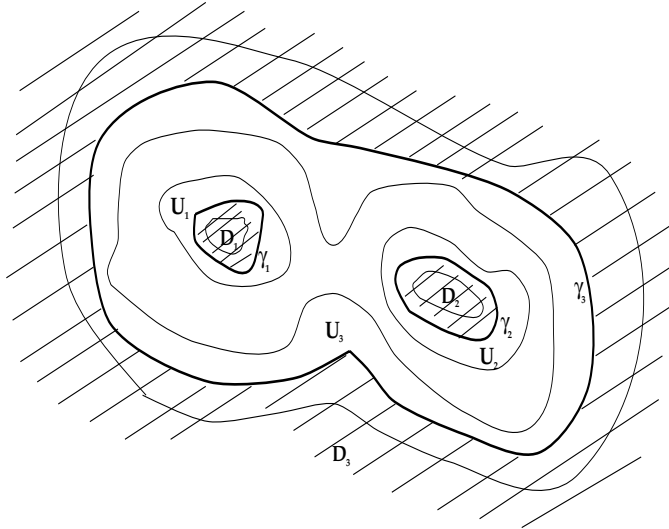

Figure 1. The interiors  $D_i$ ,  $1 \leq i \leq 2$ , and the exterior  $D_3$ .



**Proof of Theorem C.** Suppose that  $f(z)$  is a function in  $\mathbf{P}$  with an invariant Herman ring  $R$ . Thus  $f(z)$  has the form (1) for some  $\alpha$  and  $k$ .

Let  $\gamma$  be the closure of an orbit in  $R$ , where we choose  $\gamma$  to avoid the countable set of algebraic singularities of  $f^{-1}$ . Then  $\gamma$  is an analytic Jordan curve. Denote the interior of  $\gamma$  by  $I$ . We show that  $I$  contains the pole  $\alpha$  of  $f(z)$ .

Suppose  $f(z)$  is analytic in  $I$ . Then  $f(I)$  is bounded and  $\partial(f(I)) \subset f(\partial I) = f(\gamma) = \gamma$ . It follows that  $f(I) = I$  which implies that  $f^n(I) = I$  and  $I \subset F(f)$ , but  $I$  contains points of  $\partial R$  by assumption. This contradiction shows that  $I$  contains the pole  $\alpha$ .

Now  $I$  contains an orbit  $\gamma'$  of  $f(z)$  in  $R$  which is different from  $\gamma$ . Hence  $f(I)$  meets  $I$  and so  $I \subset f(I)$ . Hence there is some point  $\beta \in I$  such that  $f(\beta) = \alpha \in I$ . This contradicts the assumed form of  $f(z)$  and the theorem is proved.

#### 4. Proofs of Theorems D and E

**Proof of Theorem D.** The assertion of the Theorem D follows from Theorem A unless all  $A_i$  have connectivity two. The result is already known for  $f(z) \in \mathbf{E}$ . Further, it is known [7] that if  $f(z) \in \mathbf{P}$  the set  $F(f)$  has at most one multiply-connected component. Thus we may assume that  $f(z) \in \mathbf{M}$  and that  $A_i$  are all bounded doubly-connected domains which separate 0 from  $\infty$ .

Now  $A_1$  is a wandering component of  $F(f)$  so that the limit functions of convergent sequences  $f^{n_j}$  in  $A_1$  are necessarily constant [11]. We note that each  $A_i$  is bounded and thus the map  $f: A_i \rightarrow A_{i+1}$  is a (possibly branched) covering. In fact it follows from the Riemann–Hurwitz relation that  $f(z)$  is an unbranched  $k_i$  to 1 covering map for some  $k_i \in \mathbf{N}$ . Thus if the path  $\gamma \in A_1$  is a generator of the homotopy group of  $A_1$  the image  $\gamma_n = f^{n-1}(\gamma)$  is a path in  $A_n$  which is not homotopic to a constant. Since all limit functions of subsequences of  $f^n$  are constant in  $A_1$ , it follows that the spherical diameter of  $\gamma_n \rightarrow 0$  as  $n \rightarrow \infty$ . For any convergent subsequence  $f^{n_j}$  we have either  $\gamma_{n_j} \rightarrow \infty$  or  $\gamma_{n_j} \rightarrow 0$ . Thus at least one of  $\infty$  or 0 is a singleton component of  $J(f)$  cut off from any other point of  $J(f)$  by certain arbitrarily small curves  $\gamma_{n_j} \subset A_{n_j} \subset F(f)$ . The boundaries of  $A_{n_j}$  are in  $J(f)$  and converge to  $\infty$  or 0. If  $\infty$  is a singleton component of  $J(f)$ , then, since  $f(z) \in \mathbf{M}$ , the preimages of  $\infty$ , which are also singleton components, are dense in  $J(f)$ .

For the remaining case we may assume that no sequence  $f^{n_j} \rightarrow \infty$  in  $A_1$  and hence that the whole sequence  $f^n \rightarrow 0$  in  $A_1$ , that is the domains  $A_n \rightarrow 0$  as  $n \rightarrow \infty$ . Hence  $0 \in J(f)$  and therefore  $A_{n+1} = f(A_n) \rightarrow f(0)$  so that  $f(0) = 0$ . Then  $f(z)$  is analytic in some neighbourhood  $U$  of 0. Further,  $A_n$  is in  $U$  for  $n > n_0$  and  $A_n \rightarrow 0$  as  $n \rightarrow \infty$ . This implies that there is some  $n > n_0$  such that  $A_{n+1}$  is inside  $A_n$ , that is, in the component of  $A_n^c$  which contains 0. If  $\alpha_n$  is the outer boundary of  $A_n$  and  $I$  is the component of  $\alpha_n^c$  which contains

0, then  $f(I)$  is a bounded domain whose boundary belongs to  $f(\alpha_n) \in \partial A_{n+1}$  which is inside  $I$ . Thus  $f(I) \subset I$  and  $(f^n)$  is analytic and normal in  $I$ , but this contradicts the fact that  $0 \in J(f)$ . The proof of Theorem D is complete.

In order to prove Theorem E we need the following results.

**Lemma 3** (Runge, see for example [28]). *Suppose that  $K$  is compact in  $\mathbf{C}$  and  $f(z)$  is holomorphic on  $K$ ; further, let  $\varepsilon > 0$ . Let  $E$  be a set such that  $E$  meets every component of  $\widehat{\mathbf{C}} \setminus K$ . Then there exists a rational function  $R$  with poles in  $E$  such that*

$$|f(z) - R(z)| < \varepsilon, \quad z \in K.$$

**Lemma 4** [10]. *Suppose that  $D$  is an unbounded plane domain with at least two finite boundary points and that  $g$  is analytic in  $D$  and satisfies (i)  $g(D) \subset D$  and (ii)  $g^n(z) \rightarrow \infty$  as  $n \rightarrow \infty$ ,  $z \in D$ . Then for any  $z_0$  in  $D$  there is a constant  $k > 0$  such that*

$$\limsup \frac{1}{n} \log \log |g^n(z_0)| \leq k.$$

Further, there is a path  $\gamma$  in  $D$  and a constant  $A > 1$  such that  $\gamma$  leads to  $\infty$  and  $|z|^{1/A} \leq |g(z)| \leq |z|^A$  for all large  $z$  on  $\gamma$ .

**Proof of Theorem E.** Choose  $\varepsilon > 0$  so that

$$\frac{3}{4} < \prod_1^\infty (1 - \varepsilon^n) < \prod_1^\infty (1 + \varepsilon^n) < \frac{3}{2},$$

and a sequence  $r_n$ ,  $n \geq 2$ , so that  $r_{n+1} > 16r_n$ ,  $r_{n+1} > e^{r_n}$  and  $r_2 > 16$ . Thus the disc  $\overline{D} = \overline{D}(0, 1)$  and the annuli  $\overline{B}_n : \frac{1}{3}r_n \leq |z| \leq 3r_n$ ,  $n \geq 2$ , are all disjoint. Then  $\delta_n = r_n/r_{n+1}$ ,  $n \geq 2$ , satisfies  $0 < \delta_n < 1/16$  and  $\delta_n \rightarrow 0$  as  $n \rightarrow \infty$ .

Now choose positive numbers  $\varepsilon_1$  and  $\varepsilon_{n+1}$ ,  $n \in \mathbf{N}$ , so small that

- (2)  $(1 - 6r_{n+1}\varepsilon_{n+1}\delta_{n+1}^{-1})^{-1} < (1 + \varepsilon^n)^{1/2}$ ,
- (3)  $r_{n+2} + \varepsilon_1 < (1 + \varepsilon^n)^{1/2}r_{n+2}$ ,
- (4)  $(1 + 6r_{n+1}\varepsilon_{n+1}\delta_{n+1}^{-1})^{-1} > (1 - \varepsilon^n)^{1/2}$ ,
- (5)  $r_{n+2} - \varepsilon_1 > (1 - \varepsilon^n)^{1/2}r_{n+2}$ ,
- (6)  $\varepsilon_{n+1} < \frac{1}{2}\varepsilon_n, \quad \varepsilon_1 < \frac{1}{4}$ .

Since  $|(1 \pm \varepsilon^n)^{1/2} - 1|r_{n+2} \sim \frac{1}{2}\varepsilon^n r_{n+2} \rightarrow \infty$  as  $n \rightarrow \infty$  we may choose  $\varepsilon_1$  to satisfy (3) and (5). Then we choose  $\varepsilon_{n+1}$ ,  $n \in \mathbf{N}$ , to satisfy (2), (4), and (6).

Now define  $f_1(z) = z^{-1}$ . It follows from Lemma 3 that there is a rational function  $f_{n+1}$ ,  $n \geq 1$ , with poles only at  $\frac{1}{4}r_{n+1}$  and  $\infty$ , such that

$$(7) \quad |f_{n+1}(z)| < \varepsilon_{n+1} \quad \text{in } \overline{D}(0, \frac{1}{5}r_{n+1})$$

and

$$(8) \quad |f_1(z) + \dots + f_{n+1} - \delta_{n+1}z^{-1}| < \varepsilon_{n+1} \quad \text{in } B_{n+1}.$$

Then  $f$  defined by  $f(z) = \sum_1^\infty f_n(z)$  is meromorphic, by (6) and we have, using (7) and (8) that

$$(9) \quad |f(z) - z^{-1}| \leq \sum_2^\infty \varepsilon_n < \varepsilon_1 \quad \text{in } \bar{D},$$

$$(10) \quad |f(z) - \delta_{n+1}z^{-1}| \leq \sum_{j=n+1}^\infty \varepsilon_j < 2\varepsilon_{n+1} \quad \text{in } B_{n+1}.$$

Thus if  $1 < \lambda \leq 3$  and  $r_{n+1}\lambda^{-1} < |z| < \lambda r_{n+1}$ ,  $n \in \mathbf{N}$ , we have from (9) and (10) that

$$f(z) = \delta_{n+1}z^{-1} + \eta_n, \quad |\eta_n| < 2\varepsilon_{n+1},$$

so that  $f(z) \in D$  and

$$(11) \quad f^2(z) = \frac{z}{\delta_{n+1}}(1 + \eta_n z \delta_{n+1}^{-1})^{-1} + \eta', \quad |\eta'| < \varepsilon_1.$$

So it follows from (2), (3), (4), and (5) that

$$\begin{aligned} \lambda^{-1}r_{n+1}\delta_{n+1}^{-1}(1 + 2\lambda r_{n+1}\varepsilon_{n+1}\delta_{n+1}^{-1})^{-1} - \varepsilon_1 &< |f^2(z)| \\ &< \lambda r_{n+1}\delta_{n+1}^{-1}(1 - 2\lambda r_{n+1}\varepsilon_{n+1}\delta_{n+1}^{-1})^{-1} + \varepsilon_1, \end{aligned}$$

and hence

$$(12) \quad \lambda^{-1}r_{n+2}(1 - \varepsilon^n) < |f^2(z)| < \lambda r_{n+2}(1 + \varepsilon^n).$$

Thus if we set  $A_2 = \{z : \frac{1}{2}r_2 < |z| < 2r_2\} \subset B_2$  we find that

$$\frac{3}{8}r_{n+2} < \frac{1}{2}r_{n+2} \prod_1^\infty (1 - \varepsilon^n) < |f^{2n}(z)| < 2r_{n+2} \prod_1^\infty (1 + \varepsilon^n) < 3r_{n+2}.$$

Hence  $f^{2n}(z)$  is in  $B_{n+2}$  and so  $f^{2n}(z) \rightarrow \infty$  in  $A_2$ . Further,  $f^{2n}(A_2)$  is in some component  $\tilde{A}_{2n+2}$  of  $F(f)$ .

Again, using (2) in (11) we see that for  $z$  in  $B_{n+1}$

$$f^2(z) = \frac{z}{\delta_{n+1}}(1 + \mu) + \eta'$$

where

$$\begin{aligned} |\mu| &= |(\eta_n z \delta_{n+1}^{-1})(1 + \eta_n z \delta_{n+1}^{-1})^{-1}| \leq |(6r_{n+1} \varepsilon_n \delta_{n+1}^{-1})(1 - 6r_{n+1} \varepsilon_n \delta_{n+1}^{-1})^{-1}| \\ &\leq (1 + \varepsilon^n)^{1/2} - 1 \end{aligned}$$

and  $|\eta| < \varepsilon_1$ . It follows inductively that each  $f^{2n}(A_2)$  is a region in  $B_{n+2}$  which separates 0 and  $\infty$ . Clearly then  $\tilde{A}_{2n+2}$  which contains  $f^{2n}(A_2)$  is multiply connected. Also the components  $\tilde{A}_{2n+2}$  are all different since otherwise we have an unbounded component of  $F(f)$  which is invariant under  $f^2$  in which  $f^{2n} \rightarrow \infty$ . It follows from Lemma 4 that there is then a constant  $K$  and a curve  $\Gamma$  which tends to  $\infty$  on which  $|f^2(z)| < |z|^K$  for large  $z$ . But in any  $f^{2n}(A_2)$  we have  $|z| < 3r_{n+2}$  and  $|f^2(z)| > \frac{3}{8}r_{n+3} > \frac{3}{8}e^{r_{n+2}}$ , so no such  $\Gamma$  exists. Finally  $\tilde{A}_{2n+1} = f(\tilde{A}_{2n})$  is multiply connected. Further,  $\tilde{A}_{2n+1} \rightarrow 0$  and  $\tilde{A}_{2n+2} \rightarrow \infty$ .

## 5. Functions with finitely many poles

We will start this section by giving a theorem of H. Bohr.

**Theorem 5.1** [18]. *If  $f(z) = \sum_{n=1}^{\infty} a_n z^n$  is analytic in  $D(0, 1)$  and for some  $\varrho$ ,  $0 < \varrho < 1$ ,  $M_f(\varrho) = \text{Max}\{|f(z)| : |z| = \varrho\}$  satisfies  $M_f(\varrho) > 1$ , then  $f(D)$  contains the circle  $C_r = \{z : |z| = r\}$  for some  $r > C(\varrho)$ , where  $C(\varrho)$  is a positive constant which depends only on  $\varrho$ .*

We wish to have a similar result to Bohr's theorem for functions  $f(z)$  which are analytic in  $0 < R \leq |z| < \infty$ .

**Theorem 5.2.** *If  $f(z)$  is analytic in  $0 < R \leq |z| < \infty$  and  $M_f(r) \rightarrow \infty$  as  $r \rightarrow \infty$ , then for all sufficiently large  $\varrho$  the image  $f(A_\varrho)$  of  $A_\varrho = \{z : R \leq |z| \leq \varrho\}$  contains some circle  $C_r = \{z : |z| = r\}$  where  $r \geq cM_f(\frac{1}{2}\varrho^2)$  and  $c$  is a positive absolute constant.*

We shall use a consequence of Schottky's theorem, see e.g. [12, Lemma 1].

**Lemma 5.** *If  $g(z)$  is regular in the annulus  $A = \{z : \alpha \leq |z| \leq \beta\}$ ,  $\beta/\alpha = \gamma > 1$ , if  $g(z)$  takes neither value 0 nor 1 in  $A$ , and if for some  $|z_0| = \sqrt{\alpha\beta}$  one has  $|g(z_0)| \leq \mu$ , then there is a constant  $K$  depending only on  $\gamma$ ,  $\mu$  such that  $|g(z)| \leq K$  uniformly on  $|z| = \sqrt{\alpha\beta}$ .*

**Proof of Theorem 5.2.** I. Let  $K$  denote the constant in Lemma 5 when  $\gamma = 4$  and  $\mu = 2$ . Since  $\log M_f(r)$  is a convex function of  $\log r$ , it follows that  $M_f(r)$  can have at most one minimum in  $[R, \infty)$ , at  $s$  say, and is increasing for  $r > s$ .

Since  $M_f(r) \rightarrow \infty$  as  $r \rightarrow \infty$  we see that there is some  $T \geq R$  such that  $M_f(r) > M_f(R)$  for  $r > T$ .

Now choose  $\varepsilon = 1/2(1+3K)$ . Then there is a positive  $\varrho_0$  such that for  $\varrho \geq \varrho_0$  we have

$$\frac{1}{4}\varepsilon M_f(\frac{1}{2}\varrho) > M_f(R) \quad \text{and} \quad \varrho > 4R.$$

Suppose that for  $\varrho \geq \varrho_0$  and for every  $r \geq (\frac{1}{4}\varepsilon)M_f(\frac{1}{2}\varrho)$  there is some point on  $C_r$  which is not in  $f(A_\varrho)$ . In particular there is  $w'$  with

$$|w'| = (\frac{1}{4}\varepsilon)M_f(\frac{1}{2}\varrho)$$

and  $w''$  with

$$|w''| = (\frac{1}{2}\varepsilon)M_f(\frac{1}{2}\varrho)$$

such that  $f(z) \neq w', w''$  in  $A_\varrho$ .

There is some  $r'$  in  $R \leq r' < \frac{1}{2}\varrho$  where  $M_f(r') = |w'|$  and there is some  $z'$  with  $|z'| = r'$  and  $|f(z')| = M_f(r')$ . The point  $z'$  lies on a level curve

$$\Gamma = \{z : |f(z)| = |w'|\}.$$

Now  $\Gamma$  cannot meet  $|z| = R$  since  $(\frac{1}{4}\varepsilon)M_f(\frac{1}{2}\varrho) > M_f(R)$ . If the component  $L$  of  $\{z : |f(z)| < |w'|\}$  which contains  $\{z : R < |z| < r'\}$  lies inside  $A_\varrho$ , then we can take  $\Gamma$  to be one of the boundary curves of  $L$  which closes in  $\bar{A}_\varrho$ . Since  $\arg f(z)$  is monotone on  $\Gamma$ , it then follows that  $\arg f(z)$  changes by at least  $2\pi$  on  $\Gamma$ , that is  $f(z)$  would take every value of modulus  $|w'|$  at some point on  $\Gamma$ . Thus  $\Gamma$  meets  $\{z : |z| = \frac{1}{2}\varrho\}$  and there is some point  $z_0$  such that  $|z_0| = \frac{1}{2}\varrho$  and  $|f(z_0)| = |w'|$ .

II. Now consider

$$g(z) = \frac{f(z) - w'}{w'' - w'}$$

which is analytic in  $\{z : \frac{1}{4}\varrho < |z| < \varrho\} \subset A_\varrho$  and  $g(z) \neq 0, 1$ . Using the results in I we have

$$|g(z_0)| \leq \frac{|f(z_0)| + |w'|}{|w''| - |w'|} = \frac{2|w'|}{|w''| - |w'|} = 2.$$

It follows from Lemma 5, with  $\alpha = \frac{1}{4}\varrho$ ,  $\beta = \varrho$ , that  $|g(z)| \leq K$  uniformly on  $|z| = \sqrt{\alpha\beta} = \frac{1}{2}\varrho$ .

But on  $|z| = \frac{1}{2}\varrho$  we have uniformly

$$\begin{aligned} |f(z)| &\leq |w'| + K|w'' - w'| \leq |w'| + K(|w''| + |w'|) \\ &= M_f(\frac{1}{2}\varrho)(1 + 3K)(\frac{1}{4}\varepsilon) = \frac{1}{8}M_f(\frac{1}{2}\varrho) \end{aligned}$$

so that  $|f(z)| < M_f(\frac{1}{2}\varrho)$ , which is a contradiction. Thus the theorem holds with  $c = \frac{1}{4}\varepsilon$  where  $\varepsilon = \frac{1}{2}(1 + 3K)$ .

We shall prove Theorem F by using Theorem 5.2.

**Proof of Theorem F.** (i) Take  $R > 0$  such that  $D(0, R)$  contains the finite set of poles of  $f(z)$ . Choose  $\varrho$  so large that  $\varrho > M_f(R)$  and that  $cM_f(\frac{1}{2}\sigma) > 2\sigma$  for every  $\sigma \geq \varrho$ , where  $c$  is the constant of Theorem 5.2. If the theorem is false there is an invariant component  $G$  of  $F(f)$  and a curve  $\gamma$  which lies in  $G \cap \{z : |z| > \varrho\}$  and satisfies  $n(\gamma, 0) = 1$ . Then the annulus  $A_\varrho = \{z : R \leq |z| \leq \varrho\}$  is in the interior of  $\gamma$ .

Let  $B$  denote the region between  $C(0, R)$  and  $\gamma$  so that  $A_\varrho \subset B$ , see Figure 2.

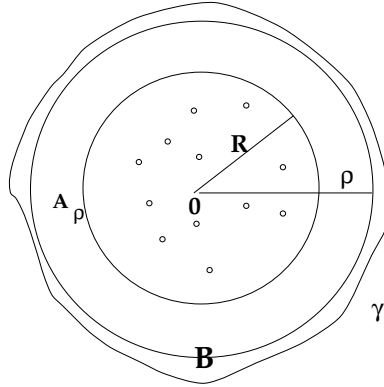

Figure 2.  $B$  is the region between  $C(0, R)$  and  $\gamma$ .

The function  $f(z)$  is analytic in  $B$ , so

$$\partial f(B) \subset f(\partial B) = f(C(0, R)) \cup f(\gamma)$$

where  $f(C(0, R)) \subset \bar{D}(0, M_f(R))$  with  $M_f(R) < \varrho$ . Since  $f(A_\varrho) \subset f(B)$  it follows from Theorem 5.2 that  $f(B)$  contains some circle  $C(0, r)$  such that  $r \geq cM_f(\frac{1}{2}\varrho) > 2\varrho$ .

The boundary of  $f(B)$ , which is compact in  $\mathbf{C}$ , contains the boundary of the unbounded component of the complement of  $f(B)$ . Thus the latter, say  $\gamma_1$  is part of  $f(\gamma)$  and is a continuum which lies in  $|z| > 2\varrho$ , and belongs to  $G$ .

We may now repeat the above argument but with  $B$  replaced by the region between  $|z| = R$  and  $\gamma_1$ , say  $B_1$  and with  $\varrho$  replaced by  $2\varrho$ . Thus  $f(B_1)$  has an ‘outer boundary’  $\gamma_2$  which is in  $|z| > 4\varrho$  and belongs to  $G$ .

Repeating this argument inductively, there is a simple closed curve  $\gamma_n$  which is part of  $f^n(\gamma)$  and contains the disc  $D(0, 2^n\varrho)$  in its interior. Then there is a compact  $K \subset \gamma$  such that  $f^n(K) \subset \gamma_n$ , for  $n \in \mathbf{N}$ , therefore  $f^n \rightarrow \infty$  on  $K$ . Since  $f^n \rightarrow \infty$  at some points of  $\gamma$ , it follows that  $f^n \rightarrow \infty$  in  $G$ .

(ii) We may assume without loss of generality that 0 and 1 are not in  $G$ . Let  $H = \widehat{\mathbf{C}} - \{0, 1, \infty\}$ ,  $\gamma_n$  be as above and let  $h = \max d_G(z, w) < \infty$  where  $z \in \gamma$ ,  $w \in \gamma_1$ , and  $d_G(z, w)$  denotes the hyperbolic distance in  $G$ .

For any  $w \in \gamma_n$  we have that  $w = f^n(z)$  for some  $z \in \gamma$  therefore

$$d_G(w, f(w)) = d_G(f^n(z), f^{n+1}(z)) \leq d_G(z, f(z)) \leq h.$$

Now  $f^n(z) \rightarrow \infty$  as  $n \rightarrow \infty$ , thus for  $w \in \gamma_n$  there is some path  $\delta$  from  $w$  to  $f(w)$  such that

$$h \geq d_G(w, f(w)) = \int_{\delta} \varrho_G(z) |dz|$$

where  $\varrho_G$  is the Poincaré density for  $G_1$ . Since  $G \subset H$  we have  $\varrho_G \geq \varrho_H$  and  $\varrho_H \sim c'/|z| \log |z|$  for some constant  $c'$ , as  $z \rightarrow \infty$ . Now

$$(13) \quad h \geq \int_{\delta} \frac{c' |dz|}{|z| \log |z|} \geq c' \int_{|w|}^{|f(w)|} \frac{d|z|}{|z| \log |z|} = c' (\log \log |f(w)| - \log \log |w|)$$

so

$$(14) \quad |f(w)| \leq |w|^p, \quad p = e^{h/c'}.$$

The inequality (14) holds for  $w \in \gamma_n$ ,  $n$  large. The function  $f(z)$  is analytic in the annulus  $R \leq |z| < \infty$ , then there are numbers  $a_j$ ,  $j \in \mathbf{Z}$ , such that

$$f(z) = \sum_{-\infty}^{\infty} a_j z^j \quad \text{in } R < |z| < \infty.$$

For an integer  $k > p$ , the function

$$F(z) = \frac{f(z)}{z^k} = \sum_{-\infty}^{\infty} a_j z^{j-k}$$

is analytic in  $R \leq |z| < \infty$ . It follows from (14) that  $\text{Sup}_{\gamma_n} |F(z)| \rightarrow 0$  as  $n \rightarrow \infty$ . Now the maximum principle implies that  $F(z)$  is bounded, say  $b$ , thus  $|F(z)| < b$  in a neighbourhood of  $\infty$  (outside  $\gamma_1$ ). Thus  $\infty$  is a removable singularity of  $F(z)$  and a pole of  $f(z)$  contrary to the assumption that  $f(z)$  is transcendental.

### 6. Orbits which tend to $\infty$

**Proof of Theorem G.** This is just part (i) of the proof of Theorem F. We note that we do not use the hypothesis that  $\gamma \subset F(f)$ , made in Theorem F until we have proved that  $f^n(\gamma)$  contains a simple closed curve  $\gamma_n$  which winds around zero and satisfies  $d(0, \gamma_n) \rightarrow \infty$ . Moreover  $\gamma_{n+1} \subset f(\gamma)$  and  $A_n = \gamma \cap f^{-n}(\gamma_n)$  is a decreasing family of compact sets whose intersection  $K$  is in  $\gamma \cap I(f)$ .

**Proof of Theorem H.** Let  $p_1$  be a pole of  $f(z)$  of order  $k$  and let  $D_1 = D(p_1, r_1)$ ,  $r_1 > 0$ . It is easy to see that  $f(D_1)$  is a neighbourhood of  $\infty$ . Since  $p_1$  is a  $k$ -fold pole of  $f(z)$ , for  $r_1$  sufficiently small there is a simply-connected neighbourhood  $V_1$  of  $p_1$  in  $D_1$  which is mapped locally univalently except at  $p_1$  onto  $|f| > R_1$ ,  $R_1 > 1$ , for some  $R_1$  ( $\bar{V}_1$  to  $|f| \geq R_1$ ). Thus we can find a pole  $p_2$  in  $\{|z| > R_1\}$  such that  $|p_2| > |p_1|$ , and a disk  $D_2 = D(p_2, r_2) \subset \{|z| > R_1\}$ ,  $r_2$  very small. By the preceding argument  $p_2 \in V_2$ , where  $V_2$  is a simply-connected neighbourhood in  $D_2$  which is mapped locally univalently by  $f$ , except at  $p_2$ , to  $\{|f| > R_2\}$  for some  $R_2 > 2R_1$ . We may take a branch of  $f^{-1}$  analytic in  $\bar{V}_2$  so that  $U_1 = f^{-1}(\bar{V}_2) \subset \bar{V}_1$ .

Using the same argument we can take a pole  $p_3$  in  $\{|z| > R_2\}$  and the disk  $D_3 = D(p_3, r_3)$ ,  $r_3$  very small, such that  $p_3 \in V_3$  where  $V_3$  is a simply-connected neighbourhood in  $D_3$  which is mapped locally univalently by  $f$ , except at  $p_3$ , to  $\{|f| > R_3\}$  where  $R_3 > 2R_2$ . We take a branch of  $f^{-1}$  analytic in  $\bar{V}_3$  so that  $f^{-1}(\bar{V}_3) \subset \bar{V}_2$ .

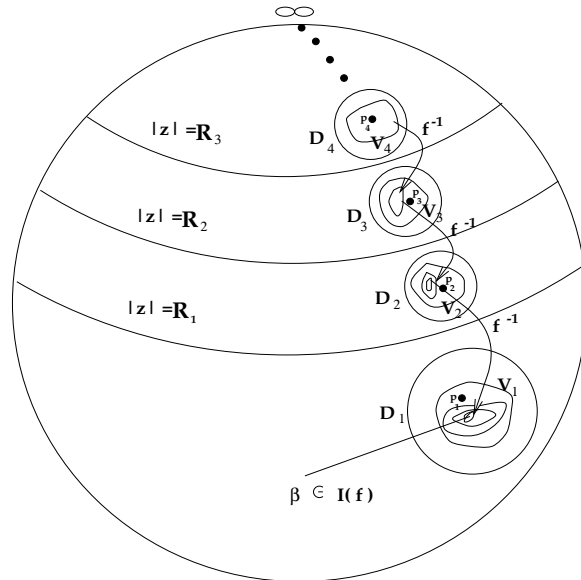

Figure 3. The process.

Repeating this process, see Figure 3, inductively we have  $D_n = D(p_n, r_n) \rightarrow \infty$  and  $f^{-n}(\bar{V}_{n+1}) = U_n \subset \bar{V}_1 \subset D_1$ ,  $n \in \mathbf{N}$ . Then  $\cap U_n \neq \emptyset$  and  $\beta \in \cap U_n$  implies  $f^n(\beta) \in D_{n+1}$ . Thus  $D_1$  contains  $\beta \in I(f)$ . The theorem is proved.

**Remark** In the above construction we have  $p_3 \in V_3$  so that  $U_2 = f^{-2}(\bar{V}_3)$  contains a point  $f^{-2}(p_3) = f^{-3}(\infty)$ . In general  $U_n$  contains a preimage  $f^{-n}(\infty)$ . We may choose the  $r_n$  so small that  $\cap U_n$  is a single point  $\beta$ . Since preimages of poles are in  $J(f)$  we then have  $\beta \in J(f)$ .



In the introduction we defined the set  $E(f)$  as the set of exceptional points of  $f(z)$ .

**Lemma 6** [9, Lemma 1]. *Let  $f(z)$  be a transcendental meromorphic function. For any  $q \in J(f)$  and any  $p$  not in  $E(f)$ ,  $q$  is an accumulation point of  $O^-(p)$ .*

**Proof of Theorem I.** It follows from Theorem G and H that  $I(f) \neq \emptyset$ . It is easy to see that  $I(f)$  is infinite since for any  $z \in I(f)$  all  $f^n(z)$ ,  $n \in \mathbf{N}$ , are different and in  $I(f)$ . Thus we can choose three different points  $\beta, \gamma, \delta$  in  $I(f)$  such that  $f(\beta) = \gamma$  and  $f(\gamma) = \delta$ . Now take a point  $\alpha$  in the Julia set and let  $V$  be a neighbourhood of  $\alpha$ . Since there are at most two exceptional points in the sense of Lemma 6 there exists a pre-image  $\alpha^*$  in  $V$  of one of the points  $\beta, \gamma, \delta$ . The point  $\alpha^*$  belongs to  $I(f)$ , so  $J(f) \subset \overline{I(f)}$ . Now periodic points are dense in  $J(f)$  and do not belong to  $I(f)$ . Hence the interior of  $I(f)$  belongs to  $F(f)$  so that  $J(f) \subset \partial I(f)$ .

To prove the opposite inclusion, take a point  $\alpha \in \partial I(f)$  and suppose that  $\alpha \in F(f)$ . Let  $V \subset F(f)$  be a neighbourhood of  $\alpha$ . Then  $V$  contains points of  $I(f)$  and all  $f^n$  are analytic in  $V$  and  $f^n \rightarrow \infty$  in  $V$ . This implies that  $V \subset I(f)$  and contradicts the assumption that  $\alpha \in \partial I(f)$ .

**Proof of Theorem J.** (i) First suppose that  $f(z)$  has only finitely many poles. Choose positive  $\varrho$  so large that  $\gamma = C(0, \varrho)$  satisfies the assumption of Theorem G. Let  $\gamma_n, A_n, K$  be as in the proof of Theorem G, so that  $K \subset I(f)$ . If  $K$  meets  $J(f)$  we are finished, so assume that  $K \subset F(f)$ . Since  $K$  is compact it is covered by some finite set  $D_1, D_2, \dots, D_p$  of components of  $F(f)$ . Since  $K = \bigcap_{n=1}^{\infty} A_n$  with  $A_n$  compact we have  $A_n \subset \bigcup_{i=1}^p D_i \subset F(f)$ ,  $n > n_0$ . But  $f^n(A_n) = \gamma_n$  so that  $\gamma_n \subset F(f)$ .

Let  $G_n$  denote the component of  $F(f)$  which contains  $\gamma_n$  so that  $f(G_n) = G_{n+1}$ , since  $f(\gamma_n)$  meets  $\gamma_{n+1}$ . If some  $G_n = G_{n+1}$ , then  $G_n$  is an unbounded invariant component of  $F(f)$  which contains arbitrarily large curves  $\gamma_m$ ,  $m \geq n > n_0$ , which wind round zero. By Theorem F this is impossible.

It follows that all  $G_n$  are different and hence bounded components of  $F(f)$ . Since  $d(0, \gamma_n) \rightarrow \infty$  as  $n \rightarrow \infty$  we see that  $f^n \rightarrow \infty$  in each  $G_k$  and also that  $G_n \rightarrow \infty$  as  $n \rightarrow \infty$ . But  $f(\partial G_n) = \partial f(G_n)$  so that each  $\partial G_k \subset I(f)$  and of course belongs to  $J(f)$ . The proof is complete in this case.

(ii) If  $f(z)$  has infinitely many poles the proof follows from the remark at the end of the proof of Theorem H, where  $\beta \in I(f) \cap J(f)$ .

## 7. Completely invariant domains

**Proof of Theorem K.** Suppose that  $F(f)$  has two mutually disjoint completely invariant domains  $G_1$  and  $G_2$  (possibly others too). Then  $G_i$ ,  $1 \leq i \leq 2$  are simply connected and infinite [11, Lemma 4.3].

Take a value  $\alpha$  in  $G_1$  such that  $f(z) = \alpha$  has infinitely many simple roots  $z_i$  ( $f'(z) = 0$  at only countably many  $z$  so we have to avoid only countably many choices of  $\alpha$ ). All  $z_i$  are in  $G_1$ .

Similarly take  $\beta$  in  $G_2$  such that  $f(z) = \beta$  has infinitely many simple roots  $z'_i$  in  $G_2$ . By Gross' star theorem [29] we can continue all the regular branches  $g_i$  of  $f^{-1}$  such that  $g_i(\alpha) = z_i$ , along almost every ray to  $\infty$  without meeting any singularity (even algebraic). Thus we can move  $\beta \in G_2$  slightly if necessary so that all  $g_i$  continue to  $\beta$  analytically along the line  $l$ , which joins  $\alpha$  and  $\beta$ . The images  $g_i(l)$  are disjoint curves joining  $z_i$  to  $z'_i$ . Denote  $g_i(l) = \gamma_i$ . Note that  $\gamma_i$  is oriented from  $z_i$  to  $z'_i$ .

The branches  $f^{-1}$  are univalent so  $\gamma_i$  are disjoint simple arcs. Different  $\gamma_i$  are disjoint since  $\gamma_i$  meets  $\gamma_j$  at say  $w_0$  only if two different branches of  $f^{-1}$  become equal with values  $w_0$  which can occur only if  $f^{-1}$  has branch point at  $f(w_0)$  in  $l$ , but this does not occur.

Take  $\gamma_1$  and  $\gamma_2$ . Since  $G_1$  is a domain we can join  $z_1$  to  $z_2$  by an arc  $\delta_1$  in  $G_1$  and similarly  $z'_1$  to  $z'_2$  by an arc  $\delta'_1$  in  $G_2$ . If  $\delta'_1$  is oriented from  $z'_1$  to  $z'_2$ , let  $p'$  be the point where, for the first time,  $\gamma_1$  meets  $\delta'_1$  and  $q'$  be the point where, for the first time,  $\gamma_2$  meets  $\delta'_1$ . If  $\delta_1$  is oriented from  $z_1$  to  $z_2$ , let  $p$  be the point where, for the last time,  $\gamma_1$  meets  $\delta_1$  and  $q$  be the point where, for the last time,  $\gamma_2$  meets  $\delta_1$ . These might look like Figure 4.

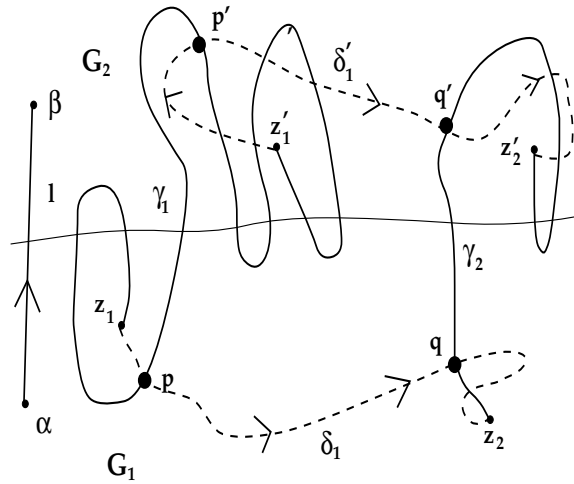

Figure 4. The arcs  $\gamma_1$ ,  $\gamma_2$ ,  $\delta_1$  and  $\delta'_1$ .

Denote by  $\beta_1$  the part of  $\delta_1$  which joins the points  $p$  and  $q$ , by  $\beta'_1$  the part of  $\delta'_1$  which joins the points  $p'$  and  $q'$ , by  $\widehat{\gamma}_1$  the part of  $\gamma_1$  which joins the points  $p$  and  $p'$ , oriented from  $p$  to  $p'$ , and by  $\widehat{\gamma}_2$  the part of  $\gamma_2$  which joins the points  $q$  and  $q'$ , oriented from  $q$  to  $q'$ . Then  $\widehat{\gamma}_1\beta'_1\widehat{\gamma}_2^{-1}\beta_1^{-1}$  is a simple closed curve  $\Gamma_1$  with an interior  $A_1$ . We assert that the function  $f(z)$  has a pole in  $A_1$ .

Suppose that  $f(z)$  is analytic in  $A_1$ , then  $f(A_1)$  is a bounded set and the frontier of  $f(A_1)$  is contained in  $f(\Gamma_1)$  and hence in  $f(\beta_1) \cup f(\beta'_1) \cup l$ .

The curves  $f(\beta_1)$  and  $f(\beta'_1)$  are closed curves lying in  $G_1$  and  $G_2$  respectively. Thus  $f(\beta_1)$  and  $f(\beta'_1)$  are mutually disjoint.

Consider the unbounded component  $H$  of the complement of  $f(\beta_1) \cup f(\beta'_1)$ . The component  $H$  meets  $l$  and in fact if  $a$  is the last point of intersection of  $l$  with  $f(\beta_1)$  and  $b$  the first point of the intersection of  $l$  with  $f(\beta'_1)$  the segment  $ab$  of  $l$  is a cross cut of  $H$  whose end points belong to different components of the frontier of  $H$ . It follows that  $ab$  does not disconnect  $H$ . Now in fact a point  $w$  of  $ab$  ( $\neq a$  or  $b$ ) is the image of  $f(z)$  of an interior point  $z$  in the arc  $\widehat{\gamma}_1$  of  $\Gamma_1$ . In the neighbourhood of  $z$  and inside  $\Gamma_1$  the function takes an open set of values near  $w$ , some of which lie off  $l$  and in  $H \setminus (ab)$ . Then since the frontier of  $A_1$  is contained in  $f(\beta_1) \cup f(\beta'_1) \cup l$  we see that  $f(A_1)$  must contain the whole of the unbounded set  $H \setminus (ab)$ . This contradiction proves that there is a pole in  $A_1$ . So far the argument closely resembles that of [8].

Now for large  $j$ ,  $\gamma_j$  does not meet  $A_1$ . Pick another pair, say  $\gamma_3$  and  $\gamma_4$ , which do not meet  $A_1 \cup \Gamma$ . Thus the points  $z_3, z_4$  are in  $G_1$  and the points  $z'_3, z'_4$  are in  $G_2$  such that  $\gamma_3$  joins  $z_3$  to  $z'_3$ , oriented from  $z_3$  to  $z'_3$ , and  $\gamma_4$  joins  $z_4$  to  $z'_4$ , oriented from  $z_4$  to  $z'_4$ .

It follows from Theorem 7.1 in [39, p. 151] that if  $z_3, z_4$  are separated in  $G_1$  by  $\Gamma_1$ , then they are separated in  $G_1$  by a component of  $G_1 \cap \Gamma_1$ , that is by a cross cut  $\varrho$ , part of  $\Gamma_1$ , in  $G_1$ . Thus  $z_3, z_4$  belong to different components of  $G_1 \setminus \varrho$  one inside  $\Gamma_1$ , in  $A_1$  say  $P_1$ , and the other outside  $\Gamma_1$ , say  $P_2$ , so we can take  $z_3 \in P_1$  and  $z_4 \in P_2$ . But  $z_3$  is outside  $A_1$  by assumption. Hence we may join  $z_3$  to  $z_4$  by an arc  $\delta_2$  in  $G_1$  which does not meet  $\Gamma_1$  or  $A_1$ . Similarly we can join  $z'_3$  to  $z'_4$  by an arc  $\delta'_2$  in  $G_2$  without meeting  $\Gamma_1$  or  $A_1$ .

Repeating the argument given before to construct the Jordan curve  $\Gamma_1$ , we can construct another Jordan curve  $\Gamma_2$ , composed of arcs of  $\gamma_3, \gamma_4, \delta_2, \delta'_2$ , which does not meet  $\Gamma_1$  or  $A_1$ . Then the interior  $A_2$  of  $\Gamma_2$  satisfies  $A_1 \cap A_2 = \emptyset$  and  $A_2$  contains a pole of  $f(z)$ .

By induction we can construct a sequence of Jordan curves  $\Gamma_i$  of the same type as  $\Gamma_1$ , with interior  $A_i$  such that the sets  $(\Gamma_i \cup A_i)$  are disjoint for different  $i$ . Having constructed  $\Gamma_1, \dots, \Gamma_i$  we choose  $\gamma_{2i+1}, \gamma_{2i+2}$  disjoint from  $\overline{A_1} \cup \dots \cup \overline{A_i}$  and can join the ends  $z_{2i+1}, z_{2i+2}$  in  $G_1$  without meeting  $\Gamma_1 \cup \dots \cup \Gamma_i$  and  $z'_{2i+1}, z'_{2i+2}$  in  $G_2$  without meeting  $\Gamma_1 \cup \dots \cup \Gamma_i$ . Each  $A_i$  contains a pole. Thus if  $F(f)$  contains more than one completely invariant component, then  $f(z)$  has infinitely many poles. The theorem is proved.

## 8. Singularities of the inverse function of a transcendental meromorphic function

We recall that the singular values of the inverse  $f^{-1}$  of a meromorphic function consist of algebraic branch points or critical values together with the asymp-

otic values along paths which tend to  $\infty$ . The latter are known as transcendental singularities.

Let  $B_j = \{z : f^j \text{ is not meromorphic at } z\}$ , so that  $B_0 = \emptyset$ ,  $B_1 = \{\infty\}$ , and  $B_j = \{\infty\} \cup f^{-1}(\infty) \cup \dots \cup f^{-(j-1)}(\infty)$  in general.

Denote  $E_n(f) = \{\text{singularities of } f^{-n}\}$ ,  $n \in \mathbf{N}$ , so that  $E_1(f)$  is the set of singularities of  $f^{-1}(z)$ . Then as shown in [31, Theorem 7.1.2],

$$f^{n-1}(E_1(f) \setminus B_{n-1}) \subseteq E_n(f) \subseteq \bigcup_{j=0}^{n-1} f^j(E_1(f) \setminus B_j).$$

Thus the set  $E(f) = \{w \in \widehat{\mathbf{C}} : \text{for some } n \in \mathbf{N}, f^{-n} \text{ has a singularity at } w\}$  is given by  $E(f) = \bigcup_{j=0}^{\infty} f^j(E_1(f) \setminus B_j)$ .

Define by  $E'(f)$  the set of points which are either accumulation points of  $E(f)$  or are singularities of some branch of  $f^{-n}$  for infinitely many values of  $n$ .

**Theorem 8.1** [31, Theorem 7.1.3]. *Let  $f(z)$  be a meromorphic function. Any constant limit function of a subsequence of  $f^n$  in a component of  $F(f)$  belongs to the set  $E(f) \cup E'(f)$ .*

For rational functions  $E(f) \cup E'(f)$  may be replaced by  $E'(f)$ . The result was proved by Fatou [26, Chapter 4, p. 60], for rational maps and modified by Baker [2] for transcendental entire functions, Bergweiler et al. [16] obtained a stronger result for entire functions. A more general result, which applies to certain classes of functions meromorphic outside a compact totally disconnected set of essential singularities, was proved by Herring [31].

**Theorem 8.2** [31, Theorem 7.1.4]. *If  $f(z)$  is a meromorphic function and  $C = \{U_0, U_1, \dots, U_{p-1}\}$  is a cycle of Siegel discs or Herman rings of  $F(f)$ , then for each  $j$ ,  $\partial U_j \subset E(f) \cup E'(f)$ . Further, in any attracting or parabolic cycles the limit functions belong to  $E'(f)$ .*

This was proved by Fatou [26, §§30–31] for rational functions and the proof in fact remains valid in our case.

We remark as a corollary (see e.g. [31, Theorem 7.1.7], if  $E(f) \cup E'(f)$  has an empty interior and connected complement, then no subsequence of  $f^n$  can have a non-constant limit function in any component of  $F(f)$ ).

As we shall see in the example of the next section, these results can be useful in proving the non-existence of wandering components of  $F(f)$  in cases where the obvious generalisation of Sullivan's theorem does not apply.

## 9. Examples

**Example 1.** If  $f \in \mathbf{E}$  is such that  $F(f)$  has an unbounded component then every component of  $F(f)$  is simply connected and  $J(f)$  has no singleton components. These results no longer hold if  $f(z)$  is allowed to have even one pole.

We show that if  $\varepsilon = 10^{-2}$ ,  $a = 1 + i\pi$ , and  $f(z) = z + 2 + e^{-z} + \varepsilon/(z - a)$ , then  $F(f)$  has a multiply-connected unbounded invariant component  $H'$ , which contains  $H$  (to be defined below), in which  $f^n \rightarrow \infty$ .

It follows from [11] that the connectivity of  $H'$  is infinite and from [20] that singleton components are everywhere dense in  $J(f)$ . We can show explicitly that for some  $x_0 < 0$  the line  $S = \{z : z = x + i\pi, -\infty < x \leq x_0\}$  is outside  $H'$ , which verifies the assertion of Theorem F.

Let  $V_\delta = \{z : |z - a| \leq \delta\}$  with  $\delta = 0.1$  and let  $G = \{z : |\operatorname{Re} z| \geq \frac{1}{2}\}$ . We can define the domain  $H$  as follows:  $H = G \cap V_\delta^c$ , see Figure 5. Thus  $H$  is unbounded and multiply connected.

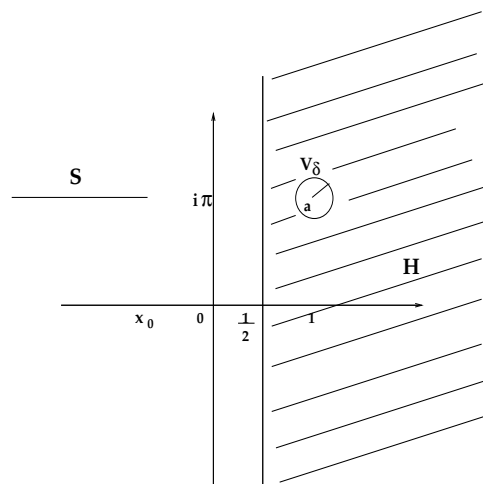

Figure 5. The domain  $H$ .

We shall prove that  $H$  is an invariant domain, that is,  $f(H) \subset H$ . Let  $z$  be in  $H$  and choose  $\varepsilon = 0.01$ . If we look at  $|e^{-z} + \varepsilon/(z - a)|$  we have

$$(15) \quad \left| e^{-z} + \frac{\varepsilon}{z - a} \right| \leq |e^{-z}| + \left| \frac{\varepsilon}{z - a} \right| \leq e^{-1/2} + \frac{\varepsilon}{\delta}.$$

Thus

$$\operatorname{Re} \left\{ z + 2 + e^{-z} + \frac{\varepsilon}{z - a} \right\} \geq \operatorname{Re}(z + 2) - \left| e^{-z} + \frac{\varepsilon}{z - a} \right| \geq \frac{1}{2} + 2 - \left( e^{-1/2} + \frac{\varepsilon}{\delta} \right) \approx 1.793.$$

Hence  $f(H) \subset H \subset F(f)$ . By similar arguments we can see that  $f^n \rightarrow \infty$ . Let  $z$  be in  $H$  as before and take  $f(z) - z = 2 + e^{-z} + \varepsilon/(z - a)$ . It follows from (15) that

$$\operatorname{Re}\{f(z) - z\} \geq 2 - e^{-1/2} - \frac{\varepsilon}{z - a} \approx 1.29 > 1.$$

Thus  $\operatorname{Re}\{f^n(z) - z\} > n \rightarrow \infty$ ,  $n \in \mathbf{N}$ , and  $f^n(z) \rightarrow \infty$ .

The component  $H'$  of  $F(f)$  which contains  $H$  thus has the properties claimed.

Since  $f(x + i\pi) = x + i\pi + 2 - e^{-x} + \varepsilon/(x - 1)$  we see that the segment  $S = \{z : z = x + i\pi, -\infty < x \leq x_0\}$  is invariant under  $f(z)$ , for some  $x_0 < -3$ . Suppose that  $z = x' + i\pi \in H' \cap S$ . Then it follows from Lemma 4 that there is some constant  $K$  such that  $\log \log |f^n(z)| < Kn$ . For a constant  $A > e^{2K}$  we have  $|\operatorname{Re} f(x + i\pi)| > |x|^A$  for  $x < x_1 < x_0$  say. Since  $f^n(x') \rightarrow \infty$  we have for some  $p \in \mathbf{N}$  that  $\operatorname{Re} f^q(x' + i\pi) < -x_1$ ,  $q \geq p$ . It follows that for  $n > p$

$$|\operatorname{Re} f^n(x' + i\pi)| > x_1^{A^{n-p}} > e^{e^{(n-p) \log A}}.$$

Thus  $\log \log |f^n(z)| > Kn$  if  $n$  is sufficiently large. This contradiction proves that  $H'$  does not meet  $S$ .

**Example 2.** For the function  $f(z) = \lambda \sin z - \varepsilon/(z - \pi)$ ,  $0 < \lambda < 1$ ,  $\varepsilon > 0$ , we wish to show that, for sufficiently small  $\varepsilon$ , the Fatou set  $F(f)$  is a single completely invariant domain of infinite connectivity. It will follow from Theorem A that singleton components are everywhere dense in  $J(f)$  but that  $J(f)$  also contains unbounded continua.

We take  $\lambda'$  so that  $\lambda < \lambda' < 1$  and  $\alpha$  so that  $0 < \alpha < 1$  and that  $\lambda |\cos z| < \lambda'$  for  $z \in S = \{z : |\operatorname{Im} z| < \alpha\}$ .

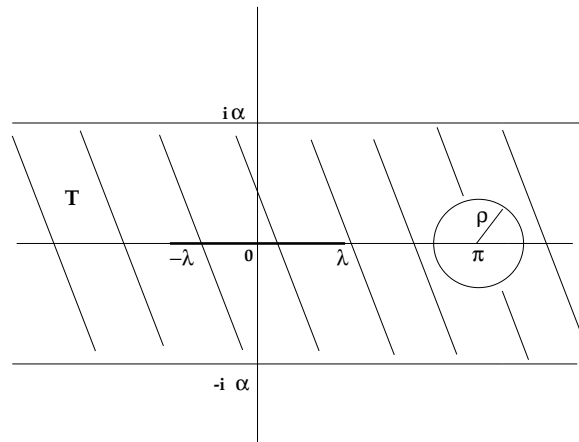

Figure 6.  $T = S \cap \{z : |z - \pi| > \varrho\}$ .

Let  $\varrho$  satisfy  $\varrho < \alpha$  and assume that  $\varepsilon$  is so small that  $\lambda'\alpha + \varepsilon\varrho^{-1} < \alpha$ . Let  $T = S \cap \{z : |z - \pi| > \varrho\}$ , see Figure 6. For  $z = x + iy \in T$  we have

$$|f(z) - \lambda \sin x| \leq \lambda |\sin z - \sin x| + \frac{\varepsilon}{|z - \pi|} \leq \lambda'\alpha + \varepsilon\varrho^{-1} < \alpha < 1.$$

Since  $\lambda \sin x \in I = [-\lambda, \lambda]$ , it follows that  $f(z)$  belongs to a compact subset of  $T$ . Thus  $T$  belongs to an invariant component  $H$  of  $F(f)$  in which  $f^n(z) \rightarrow \beta$  where  $\beta$  is an attracting fixed point of  $f(z)$ .

Now we consider the singular points of  $f^{-1}$ . On any path  $\Gamma$  which tends to  $\infty$ ,  $\varepsilon(z - \pi)^{-1} \rightarrow 0$  and  $f(z)$  has a limit  $l$  if and only if  $\lambda \sin z \rightarrow l$ . This is possible only for  $l = \infty$ . Thus apart from  $\infty$  all singularities of  $f^{-1}$  are finite critical values of  $f(z)$ .

If  $f'(z) = 0$  and  $|z - \pi| > t = \frac{1}{4}\pi$ , then

$$|\cos z| < \varepsilon \lambda^{-1} t^{-2} < 2\varepsilon \lambda^{-1}, \quad \sin z = \pm(1 + \eta)$$

where  $|\eta| < 2\varepsilon^2 \lambda^{-2}$  (if  $\varepsilon$  was originally chosen small enough). For any such  $z$  we have  $|f(z) - \lambda \sin z| < 4\varepsilon/\pi$  and so  $|f(z) \pm \lambda| < 2\varepsilon^2 \lambda^{-1} + 4\varepsilon/\pi$ . Thus we have  $f(z) \in T \subset H$  (if  $\varepsilon$  was chosen small enough).

If  $f'(z) = 0$  and  $|z - \pi| \leq t = \frac{1}{4}\pi$ , then

$$\frac{\varepsilon}{(\lambda e^{\pi/4})} \leq |(z - \pi)^2| = \left| \frac{\varepsilon}{(\lambda \cos z)} \right| \leq \frac{\sqrt{2}\varepsilon}{\lambda},$$

since

$$|\cos z| \geq |\cos x \cosh y| \geq 1/\sqrt{2} \quad \text{and} \quad |\cos z| < e^{|y|}.$$

Thus  $|z - \pi| < 2^{1/4} \sqrt{\varepsilon} \sqrt{1/\lambda}$ ,  $|\sin z| < 2\sqrt{\varepsilon} \sqrt{1/\lambda}$ ,  $\varepsilon|z - \pi|^{-1} < \sqrt{\varepsilon} \sqrt{\lambda} e$ , and  $|f(z)| < 2\sqrt{\varepsilon} \sqrt{\lambda} + \sqrt{\varepsilon} \sqrt{\lambda} e$ , so that  $f(z) \in T \subset H$ , provided  $\varepsilon$  was chosen small enough.

Thus the set  $E_1(f)$  of the singularities of  $f^{-1}(z)$  consists of a countable subset of  $T$  whose closure is compact in  $T$ , together with  $\infty$ . The same is true of the sets  $E(f)$  and  $E'(f)$  defined in Section 8 and  $E(f) \cup E'(f) = \bigcup_0^\infty f^j(E_1(f) \setminus \{\infty\}) \cup \{\beta, \infty\}$ . It follows from the results of Section 8 that there are no Siegel discs or Herman rings. The only cyclic component of  $F(f)$  is  $H$ .

All singularities (except  $\infty$ ) of  $f^{-1}$  are contained in  $H$ . Take a point  $z_0$  in  $H$  and a branch  $g$  of  $f^{-1}$  such that  $g(z_0) \in H$ . For any  $z_1$  in  $H$  and any branch  $h$  of  $f^{-1}$  at  $z_1$  we can reach  $h(z_1)$  by analytic continuation of  $g$  along a path  $\gamma$  from  $z_0$  to  $z_1$ . Now  $\gamma$  is homotopic to a path from  $\gamma$  in  $\mathbf{C} \setminus E_1(f)$  to a path  $\gamma_1$  from  $z_0$  to  $z_1$ , and the continuation of  $g$  along  $\gamma_1$  is  $h$  at  $z_1$ . But  $g(\gamma_1) \subset F(f)$  and hence  $g(\gamma_1) \subset H$ . Thus  $H$  is completely invariant.

The only possible constant limits of sequences  $f^{n_k}$  in Fatou components are  $\beta$  and  $\infty$ . The only possible components  $G$  of  $F(f)$  other than  $H$  will be wandering components in which  $f^n \rightarrow \infty$  as  $n \rightarrow \infty$ . Now we shall show that no such domains  $G$  exist.

If there is such  $G$  we may suppose that  $f^n(G)$  does not meet  $D(\pi, \rho)$  for any  $\mathbf{N}$ , since  $f^n(G) \rightarrow \infty$ . We must have  $\text{Im } f^n \rightarrow \infty$  in  $G$  and hence also  $f'(f^n) \rightarrow \infty$  and  $(f^n)' \rightarrow \infty$  in  $G$ . It follows from Bloch's theorem that  $f^{n+1}(G)$

contains some discs  $D(a, 4\pi)$ , where  $|\operatorname{Im} a|$  can be taken arbitrarily large, but then on the horizontal diameter of  $D(a, \pi)$ ,  $f(z) \sim \frac{1}{2}e^{-ix+y}$  so that  $f^{n+2}(G)$  contains some real points, which must be in  $H$ . This is impossible, so there are no such domains  $G$ .

We have now proved our claim that  $F(f) = H$  which is multiply connected, since  $\pi$  is not in  $F(f)$ . Then  $H$  must in fact have infinite connectivity and by Theorem A the singleton components of  $J(f)$  are everywhere dense in  $J(f)$ . It follows from the corollary to Theorem F that the Julia set  $J(f)$  has some components which are not singletons. We show that this is true of the component which contains  $\infty$  that is, there exist unbounded components of  $J(f)$ . It follows from Theorem F that if  $R$  is a sufficiently large positive number, then there is no curve  $\gamma$  in  $F(f) \cap \overline{D}(0, R)^c$  which winds round zero. This implies that the component  $K$  of the closed set  $J(f) \cup \overline{D}(0, R)$ , which contains  $\infty$ , is not a singleton.

If  $K \subset J(f)$ , then we are finished. If not we can take a point  $w$  in  $K \cap \overline{D}(0, R)$  and for each  $\varepsilon = 1/n$  we may form an  $\varepsilon$ -chain (in the spherical metric) in the connected compact set  $K$  which starts at  $\infty$  and ends at  $w$ . Denote by  $A_n$  the set  $\{z_1^n = \{\infty\}, z_2^n, \dots, z_{j(n)}^n\}$  where  $z_{j(n)+1}^n$  is the first point of the chain which lies in  $\overline{D}(0, R)$ . Thus  $A_n \subset J(f)$ . Since  $\infty \in \liminf A_n \neq \emptyset$ , we deduce that  $L = \limsup A_n = \{z : \text{a neighbourhood of } z \text{ meets infinitely many } A_n\}$  is connected (see e.g. [43]). But  $L \subset J(f)$ ,  $\infty \in L$  and  $L$  meets  $C(0, R)$ . Thus  $\{\infty\}$  is not a singleton component of  $J(f)$ , that is,  $J(f)$  has an unbounded component.

For  $g(z) = \lambda \sin z$  the Julia set contains segments  $\pm\{z : z = iy, 0 < y_0 < y < \infty\}$  of the imaginary axis. For  $f(z)$  one can show by direct discussion that  $J(f)$  contains continua which are 'close to' the above segments. We omit the discussion.

### References

- [1] BAKER, I.N.: Multiply-connected domains of normality in iteration theory. - Math. Z. 81, 1963, 206–214.
- [2] BAKER, I.N.: Limit functions and set of non-normality in iteration theory. - Ann. Acad. Sci. Fenn. Ser. A I Math. 467:1, 1970.
- [3] BAKER, I.N.: The domains of normality of an entire function. - Ann. Acad. Sci. Fenn. Ser. A I Math. 1, 1975, 277–283.
- [4] BAKER, I.N.: An entire function which has wandering domains. - J. Austral. Math. Soc. Ser. A. 22, 1976, 173–176.
- [5] BAKER, I.N.: Wandering domains in the iteration of entire functions. - Proc. London Math. Soc. (3) 49, 1984, 563–576.
- [6] BAKER, I.N.: Some entire functions with multiply-connected wandering domains. - Ergodic Theory Dynamical Systems 5, 1985, 163–169.
- [7] BAKER, I.N.: Wandering domains for maps of the punctured plane. - Ann. Acad. Sci. Fenn. Ser. A I Math. 12, 1987, 191–198.
- [8] BAKER, I.N.: Completely invariant domains of entire functions. - In: Mathematical Essays Dedicated to A.J. MacIntyre, Ohio University Press, Athens, Ohio, 1970, 33–35.



- [9] BAKER, I.N., J. KOTUS, and LÜ YINIAN: Iterates of meromorphic functions I. - Ergodic Theory Dynamical Systems 11, 1991, 241–248.
- [10] BAKER, I.N., J. KOTUS, and LÜ YINIAN: Iterates of meromorphic functions II: Examples of wandering domains. - J. London Math. Soc. (2) 42, 1990, 267–278.
- [11] BAKER, I.N., J. KOTUS, and LÜ YINIAN: Iterates of meromorphic functions III. Preperiodic domains. - Ergodic Theory Dynamical Systems 11, 1991, 603–618.
- [12] BAKER, I.N., and L.S.O. LIVERPOOL: Picard sets for entire functions. - Math. Z. 126, 1972, 230–238.
- [13] BEARDON, A.F.: Iteration of Rational Functions. - Graduate Texts in Math. 132, Springer-Verlag, New York, 1991.
- [14] BERGWELER, W.: Iteration of meromorphic functions. - Bull. Amer. Math. Soc. (N.S.) 29, 1993, 151–188.
- [15] BERGWELER, W.: On the Julia set of analytic self-maps of the punctured plane. - Analysis 15, 1995, 251–256.
- [16] BERGWELER, W., M. HARUTA, H. KRIETE, H.-G. MEIER, and N. TERGLANE: On the limit functions of iterates in wandering domains. - Ann. Acad. Sci. Fenn. Ser. A I Math. 18, 1993, 369–375.
- [17] BHATTACHARYYA, P.: Iteration of analytic functions. - PhD thesis, University of London, 1969.
- [18] BOHR, H.: Über einen Satz von Edmund Landau. - Scripta Univ. Hierosolymitararum 1, 1923.
- [19] DEVANEY, R.L., and L. KEEN: Dynamics of meromorphic maps with polynomial Schwarzian derivative. - Ann. Sci. École Norm. Sup (4) 22, 1989, 55–81.
- [20] DOMÍNGUEZ, P.: Connectedness properties of Julia set of transcendental entire functions. - Complex Variables Theory Appl. 32, 1997, 199–215.
- [21] EREMENKO, A.E.: On the iteration of entire functions. - Dynamical Systems and Ergodic Theory, Banach Center Publications, 23, 1989, 339–345.
- [22] EREMENKO, A.E., and M.YU. LYUBICH: Dynamical properties of some classes of entire functions. - Ann. Inst. Fourier (Grenoble) 42, 1992, 989–1020.
- [23] FANG, L.: Complex dynamical systems on  $C^*$ . - Acta Math. Sinica 34, 1991, 611–621 (Chinese).
- [24] FANG, L.: Area of Julia sets of holomorphic self-maps. - Acta Math. Sinica (N.S.) 9, 1993, 160–165.
- [25] FANG, L.: On the iterations of holomorphic self-maps of  $C^*$ . - Preprint.
- [26] FATOU, P.: Sur les équations fonctionnelles. - Bull. Soc. Math. France 47, 1919, 161–271 and 48, 1920, 33–94, 208–314.
- [27] FATOU, P.: Sur l'itération des fonctions transcendentes entières. - Acta Math. 47, 1926, 337–370.
- [28] GAIER, D.: Lectures on Complex Approximation. - Birkhäuser, Boston, 1985.
- [29] GROSS, W.: Über die Singularitäten analytischer Funktionen. - Monats. Math. Physik 29, 1918, 3–47.
- [30] HAYMAN, W.K.: Meromorphic Functions. - Oxford Mathematical Monographs, Oxford University Press 1964.
- [31] HERRING, M.E.: An extension of the Julia–Fatou theory of the iteration. - PhD thesis, University of London, 1994.

- [32] KEEN, L.: Dynamics of holomorphic self-maps of  $C^*$ . - In: *Holomorphic Functions and Moduli I*, edited by D. Drasin, C.J. Earle, F.W. Gehring, I. Kra and A. Marden, Springer-Verlag, New York–Berlin–Heidelberg, 1988, 9–30.
- [33] KEEN, L.: Topology and growth of special class of holomorphic self-maps of  $C^*$ . - *Ergodic Theory Dynamical Systems* 9, 1989, 321–328.
- [34] KOTUS, J.: Iterated holomorphic maps of the punctured plane in dynamical systems. - In: *Lecture Notes Econom. and Math. Systems* 287, Springer-Verlag, Berlin–Heidelberg–New York, 1987, 10–29.
- [35] KOTUS, J.: The domains of normality of holomorphic self-maps of  $C^*$ . - *Ann. Acad. Sci. Fenn. Ser. A I Math.* 15, 1990, 329–340.
- [36] MAKIENKO, P.M.: Iterates of analytic functions of  $C^*$ . - *Soviet Math. Dokl.* 36, 1988, 418–420. Translation from *Dokl. Akad. Nauk. SSSR* 297, 1987.
- [37] MAKIENKO, P.M.: Herman rings in the theory of iterations of endomorphisms of  $C^*$ . - *Siberian Math. J.* 32, 1991, 431–436. Translation from *Sibirsk. Math. Zh.* 32, 1991, 97–103.
- [38] MUKHAMEDSHIN, A.N.: Mapping the punctured plane with wandering domains. - *Siberian Math. J.* 32, 1991, 337–339. Translation from *Sibirsk. Math. Zh.* 32, 1991, 184–187.
- [39] NEWMAN, M.H.A.: *Elements of the Topology of Plane Set of Points.* - Cambridge University Press, 1954.
- [40] PÓLYA, G.: On an integral function of an integral function. - *J. London Math. Soc.* 1, 1926, 12–15.
- [41] RÅDSTRÖM, H.: On the iterations of analytic functions. - *Math. Scand.* 1, 1953, 85–92.
- [42] TSUJI, M.: *Potential Theory in Modern Function Theory.* - Maruzen, Tokyo, 1959.
- [43] WHYBURN, G., and E. DUDA: *Dynamic Topology.* - Springer-Verlag, New York–Heidelberg–Berlin, 1979.

Received 29 October 1996