

DAVID MAPS AND HAUSDORFF DIMENSION

Saeed Zakeri

Stony Brook University, Institute for Mathematical Sciences
Stony Brook, NY 11794-3651, U.S.A.; zakeri@math.sunysb.edu

Abstract. David maps are generalizations of classical planar quasiconformal maps for which the dilatation is allowed to tend to infinity in a controlled fashion. In this note we examine how these maps distort Hausdorff dimension. We show:

– Given α and β in $[0, 2]$, there exists a David map $\varphi: \mathbf{C} \rightarrow \mathbf{C}$ and a compact set Λ such that $\dim_H \Lambda = \alpha$ and $\dim_H \varphi(\Lambda) = \beta$.

– There exists a David map $\varphi: \mathbf{C} \rightarrow \mathbf{C}$ such that the Jordan curve $\Gamma = \varphi(\mathbf{S}^1)$ satisfies $\dim_H \Gamma = 2$.

One should contrast the first statement with the fact that quasiconformal maps preserve sets of Hausdorff dimension 0 and 2. The second statement provides an example of a Jordan curve with Hausdorff dimension 2 which is (quasi)conformally removable.

1. Introduction

An orientation-preserving homeomorphism $\varphi: U \rightarrow V$ between planar domains is called *quasiconformal* if it belongs to the Sobolev class $W_{\text{loc}}^{1,1}(U)$ (i.e., has locally integrable distributional partial derivatives in U) and its complex dilatation $\mu_\varphi := \bar{\partial}\varphi/\partial\varphi$ satisfies

$$\|\mu_\varphi\|_\infty < 1.$$

In terms of the real dilatation defined by

$$K_\varphi := \frac{1 + |\mu_\varphi|}{1 - |\mu_\varphi|} = \frac{|\partial\varphi| + |\bar{\partial}\varphi|}{|\partial\varphi| - |\bar{\partial}\varphi|},$$

the above condition can be expressed as

$$\|K_\varphi\|_\infty < +\infty.$$

The quantity $\|K_\varphi\|_\infty$ is called the *maximal dilatation* of φ . We say that φ is K -quasiconformal if its maximal dilatation does not exceed K .

For later comparison with the properties of David maps defined below, we recall some basic properties of quasiconformal maps (see [A] or [LV]):

– If φ is K -quasiconformal for some $K \geq 1$, so is the inverse map φ^{-1} .

- A K -quasiconformal map $\varphi: U \rightarrow V$ is locally Hölder continuous of exponent $1/K$. In other words, for every compact set $E \subset U$ and every $z, w \in E$,

$$|\varphi(z) - \varphi(w)| \leq C|z - w|^{1/K}$$

where $C > 0$ only depends on E and K .

- A quasiconformal map $\varphi: U \rightarrow V$ is absolutely continuous; in fact, the Jacobian $J_\varphi = |\partial\varphi|^2 - |\bar{\partial}\varphi|^2$ is locally integrable in U and

$$(1.1) \quad \text{area } \varphi(E) = \int_E J_\varphi \, dx \, dy,$$

for every measurable set $E \subset U$.

- More precisely, the Jacobian J_φ of a quasiconformal map $\varphi: U \rightarrow V$ is in $L^p_{\text{loc}}(U)$ for some $p > 1$. If we define

$$(1.2) \quad p(K) := \sup\{p : J_\varphi \in L^p_{\text{loc}}(U) \text{ for every } K\text{-quasiconformal map } \varphi \text{ in } U\},$$

then

$$(1.3) \quad p(K) = \frac{K}{K-1}.$$

(In particular, $p(K)$ is independent of the domain U .) This was conjectured by Gehring and Väisälä in 1971 [GV] and proved by Astala in 1994 [As].

- Let $\{\varphi_n\}$ be a sequence of K -quasiconformal maps in a planar domain U which fix two given points of U . Then $\{\varphi_n\}$ has a subsequence which converges locally uniformly to a K -quasiconformal map in U .

The measurable Riemann mapping theorem of Morrey–Ahlfors–Bers [AB] asserts that every measurable function μ in a domain U which satisfies $\|\mu\|_\infty < 1$ is the complex dilatation of some quasiconformal map φ in U , which means φ satisfies the *Beltrami equation* $\bar{\partial}\varphi = \mu \cdot \partial\varphi$ almost everywhere in U . Recent progress in holomorphic dynamics has made it abundantly clear that one must also study this equation in the case $\|\mu\|_\infty = 1$. With some restrictions on the asymptotic growth of $|\mu|$, the solvability of the Beltrami equation can still be guaranteed. One such condition is given by David in [D]. Let σ denote the spherical area in $\widehat{\mathbb{C}}$ and μ be a measurable function in U which satisfies

$$(1.4) \quad \sigma\{z \in U : |\mu(z)| > 1 - \varepsilon\} \leq C \exp\left(-\frac{t}{\varepsilon}\right) \quad \text{for all } \varepsilon < \varepsilon_0$$

for some positive constants C, t, ε_0 . Then David showed that the Beltrami equation $\bar{\partial}\varphi = \mu \cdot \partial\varphi$ has a homeomorphic solution $\varphi \in W^{1,1}_{\text{loc}}(U)$ which is unique up to postcomposition with a conformal map (see also [BJ] for a more geometric

approach which gives a stronger theorem). Motivated by this result, we call a homeomorphism $\varphi: U \rightarrow V$ a *David map* if $\varphi \in W_{\text{loc}}^{1,1}(U)$ and the complex dilatation μ_φ satisfies a condition of the form (1.4). Equivalently, φ is a David map if there are positive constants C, t, K_0 such that its real dilatation satisfies

$$(1.5) \quad \sigma\{z \in U : K_\varphi(z) > K\} \leq Ce^{-tK} \quad \text{for all } K > K_0.$$

To emphasize the values of these constants, sometimes we say that φ is a (C, t, K_0) -David map. Note that when U is a bounded domain in \mathbf{C} , the spherical metric in (1.4) or (1.5) can be replaced with the Euclidean area.

David maps enjoy some of the useful properties of quasiconformal maps, but the two classes differ in many respects. As indications of their similarity, let us mention the following two facts:

- Every David map is absolutely continuous; the Jacobian formula (1.1) still holds.
- *Tukia's theorem* [T]. “Let C, t, K_0 be positive and suppose $\{\varphi_n\}$ is a sequence of (C, t, K_0) -David maps in a domain U which fix two given points of U . Then $\{\varphi_n\}$ has a subsequence which converges locally uniformly to a David map in U .” It is rather easy to show that some subsequence of $\{\varphi_n\}$ converges locally uniformly to a homeomorphism, but the fact that this homeomorphism must be David is quite non-trivial. We remark that the parameters of the limit map may a priori be different from C, t, K_0 .

Here are further properties of David maps which indicate their difference with quasiconformal maps:

- The inverse of a David map may not be David.
- A David map may not be locally Hölder.
- The Jacobian of a David map may not be in $L_{\text{loc}}^p(U)$ for any $p > 1$.

As an example, the homeomorphism $\varphi: \mathbf{D}(0, 1/e) \rightarrow \mathbf{D}$ defined by

$$\varphi(re^{i\theta}) := -\frac{1}{\log r} e^{i\theta}$$

is a David map but φ^{-1} is not. Moreover, φ is not Hölder in any neighborhood of 0, and $J_\varphi \notin L_{\text{loc}}^p$ for $p > 1$.

The main goal of this note is to show how David maps differ from quasiconformal maps in the way they distort Hausdorff dimension of sets. Recall that the *Hausdorff s -measure* of $E \subset \mathbf{C}$ is defined by

$$H^s(E) := \liminf_{\varepsilon \rightarrow 0} \sum_i (\text{diam } U_i)^s,$$

where the infimum is taken over all countable covers $\mathcal{U} = \{U_i\}$ of E by sets of Euclidean diameter at most ε . The *Hausdorff dimension* of E is defined by

$$\dim_H E := \inf\{s : H^s(E) = 0\}.$$

Quasiconformal maps can change Hausdorff dimension of sets only by a bounded factor depending on their maximal dilatation. This was first proved by Gehring and Väisälä [GV] who showed that if $\varphi: U \rightarrow V$ is K -quasiconformal, $E \subset U$, $\dim_H E = \alpha$ and $\dim_H \varphi(E) = \beta$, then

$$\frac{2(p(K) - 1)\alpha}{2p(K) - \alpha} \leq \beta \leq \frac{2p(K)\alpha}{2(p(K) - 1) + \alpha}.$$

Here $p(K) > 1$ is the constant defined in (1.2). By Astala's result (1.3), one obtains

$$\frac{2\alpha}{2K - (K - 1)\alpha} \leq \beta \leq \frac{2K\alpha}{2 + (K - 1)\alpha}$$

which can be put in the symmetric form

$$(1.6) \quad \frac{1}{K} \left(\frac{1}{\alpha} - \frac{1}{2} \right) \leq \frac{1}{\beta} - \frac{1}{2} \leq K \left(\frac{1}{\alpha} - \frac{1}{2} \right).$$

It follows in particular that quasiconformal maps preserve sets of Hausdorff dimension 0 and 2.

By contrast, we prove

Theorem A. *Given any two numbers α and β in $[0, 2]$, there exists a David map $\varphi: \mathbf{C} \rightarrow \mathbf{C}$ and a compact set $\Lambda \subset \mathbf{C}$ such that $\dim_H \Lambda = \alpha$ and $\dim_H \varphi(\Lambda) = \beta$.*

The proof shows that the parameters of φ can be taken independent of α and β .

In the special case of a K -quasircle, i.e., the image Γ of the round circle under a K -quasiconformal map, the estimate (1.6) gives

$$1 \leq \dim_H \Gamma \leq \frac{2K}{K + 1}$$

(the lower bound comes from topological considerations). It is well known that $\dim_H \Gamma$ can in fact take all values in $[1, 2)$. We show that the upper bound 2 is attained by a David image of the round circle. Let us call a Jordan curve $\Gamma \subset \mathbf{C}$ a *David circle* if there exists a David map $\varphi: \mathbf{C} \rightarrow \mathbf{C}$ such that $\Gamma = \varphi(\mathbf{S}^1)$, where \mathbf{S}^1 is the unit circle $\{z \in \mathbf{C} : |z| = 1\}$.

Theorem B. *There exist David circles of Hausdorff dimension 2.*

One corollary of this result is that there are Jordan curves of Hausdorff dimension 2 that are (quasi)conformally removable (see Section 4).

Both results are bad (or exciting?) news for applications in holomorphic dynamics, where one often wants to estimate the Hausdorff dimension of invariant

sets by computing the dimension in a conjugate dynamical system. The dichotomy of having dimension < 2 or $= 2$ for such invariant sets, which is respected by quasiconformal conjugacies, is no longer preserved by David conjugacies. For example, by performing a quasiconformal surgery on a Blaschke product, Petersen proved that the Julia set of the quadratic polynomial $Q_\theta: z \mapsto e^{2\pi i\theta}z + z^2$ is locally-connected and has measure zero whenever θ is an irrational of bounded type [P]. In this case, the boundary of the Siegel disk of Q_θ is a quasicircle whose Hausdorff dimension is strictly between 1 and 2 (compare [GJ]). On the other hand, by performing a *trans-quasiconformal* surgery and using David's theorem, Petersen and the author extended the above result to almost every θ [PZ]. It follows that there exists a full-measure set of rotation numbers θ for which the boundary of the Siegel disk of Q_θ is a David circle but not a quasicircle. Thus, Theorem B opens the possibility that this boundary alone might have dimension 2, which would be a rather curious phenomenon.

2. Preliminary constructions

For two positive numbers a and b , we write

$$a \preceq b$$

if there is a universal constant $C > 0$ such that $a \leq Cb$. We write

$$a \asymp b$$

if $a \preceq b$ and $b \preceq a$, i.e., if there is a universal constant $C > 0$ such that $C^{-1}b \leq a \leq Cb$. In this case, we say that a and b are *comparable*.

A family of Cantor sets. Given a strictly decreasing sequence $\mathbf{d} = \{d_n\}_{n \geq 0}$ of positive numbers with $d_0 = 1$, we construct a Cantor set $\Lambda(\mathbf{d})$ as the intersection of a nested sequence $\{\Lambda_n\}_{n \geq 0}$ of compact sets in the unit square $\Lambda_0 := [-\frac{1}{2}, \frac{1}{2}] \times [-\frac{1}{2}, \frac{1}{2}]$ defined inductively as follows. Set $a_1 := 2^{-2}(d_0 - d_1)$ and define Λ_1 as the disjoint union of the four closed squares of side-length $2^{-1}d_1$ in Λ_0 which have distance a_1 to the boundary of Λ_0 (see Figure 1). Suppose Λ_{n-1} is constructed for some $n \geq 2$ so that it is the disjoint union of 4^{n-1} closed squares of side-length $2^{-(n-1)}d_{n-1}$. Define

$$(2.1) \quad a_n := 2^{-(n+1)}(d_{n-1} - d_n).$$

For any square S in Λ_{n-1} , consider the disjoint union of the four closed squares in S of side-length $2^{-n}d_n$ which have distance a_n to the boundary of S . The union of all these squares for all such S will then be called Λ_n . Clearly Λ_n is

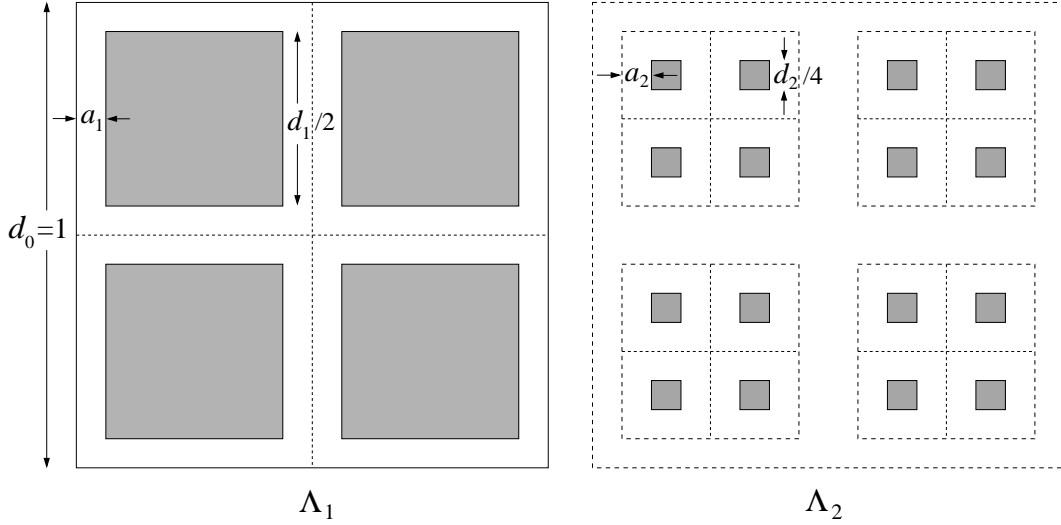

Figure 1. First two steps in the construction of $\Lambda(\mathbf{d})$.

the disjoint union of 4^n closed squares of side-length $2^{-n}d_n$, and the inductive definition is complete.

The Cantor set $\Lambda(\mathbf{d})$ is defined as $\bigcap_{n \geq 0} \Lambda_n$. We have

$$\text{area } \Lambda(\mathbf{d}) = \lim_{n \rightarrow \infty} \text{area } \Lambda_n = \lim_{n \rightarrow \infty} d_n^2.$$

Lemma 2.1. *The Hausdorff dimension of the Cantor set $\Lambda = \Lambda(\mathbf{d})$ satisfies*

$$(2.2) \quad 2 - \limsup_{n \rightarrow \infty} \frac{-2 \log d_{n+1}}{-\log d_n + n \log 2} \leq \dim_H \Lambda \leq 2 - \liminf_{n \rightarrow \infty} \frac{-2 \log d_n}{-\log d_n + n \log 2}.$$

Proof. For each $n \geq 0$, there are 4^n squares of diameter $2^{(1/2)-n}d_n$ covering Λ . Hence the Hausdorff s -measure of Λ is bounded above by

$$\liminf_{n \rightarrow \infty} 4^n (2^{(1/2)-n}d_n)^s = 2^{s/2} \liminf_{n \rightarrow \infty} 2^{n(2-s)} d_n^s,$$

which is zero if $s > 2 - \liminf_{n \rightarrow \infty} (-2 \log d_n) / (-\log d_n + n \log 2)$. This proves the upper bound in (2.2).

The lower bound follows from a standard mass distribution argument: Construct a probability measure μ on Λ which gives equal mass 4^{-n} to each square in Λ_n , so that

$$\mu(S) = \frac{\text{area}(S)}{d_n^2} \quad \text{if } S \text{ is a square in } \Lambda_n.$$

Let $x \in \Lambda$ and $\varepsilon > 0$, and choose n so that $2^{-n}d_n < \varepsilon \leq 2^{-(n-1)}d_{n-1}$. The disk $\mathbf{D}(x, \varepsilon)$ intersects at most $\pi \varepsilon^2 / (4^{-n}d_n^2)$ squares in Λ_n each having μ -mass of 4^{-n} . It follows that

$$\mu(\mathbf{D}(x, \varepsilon)) \leq \frac{\varepsilon^2}{d_n^2} = \varepsilon^s \frac{\varepsilon^{2-s}}{d_n^2} \leq \varepsilon^s \frac{2^{-n(2-s)} d_{n-1}^{2-s}}{d_n^2}.$$

If $s < 2 - \limsup_{n \rightarrow \infty} (-2 \log d_{n+1}) / (-\log d_n + n \log 2)$, the term $2^{-n(2-s)} d_{n-1}^{2-s} / d_n^2$ will tend to zero as $n \rightarrow \infty$, so that

$$\mu(\mathbf{D}(x, \varepsilon)) \asymp \varepsilon^s.$$

It follows from Frostman's lemma (see for example [M]) that $\dim_H \Lambda \geq s$. This gives the lower bound in (2.2). \square

Standard homeomorphisms between Cantor sets. We construct standard homeomorphisms with controlled dilatation between Cantor sets of the form $\Lambda(\mathbf{d})$ defined above. The construction will depend on the following lemma:

Lemma 2.2. *Fix $0 < a \leq b < \frac{1}{2}$. Let A_a be the closed annulus bounded by the squares*

$$\{(x, y) \in \mathbf{R}^2 : \max\{|x|, |y|\} = \frac{1}{2}\} \quad \text{and} \quad \{(x, y) \in \mathbf{R}^2 : \max\{|x|, |y|\} = \frac{1}{2} - a\},$$

and similarly define A_b . Let $\varphi: \partial A_a \rightarrow \partial A_b$ be a homeomorphism which is the identity on the outer boundary component and acts affinely on the inner boundary component, respecting the horizontal and vertical sides. Then φ can be extended to a K -quasiconformal homeomorphism $A_a \rightarrow A_b$, with

$$(2.3) \quad K \asymp \frac{b(1-2a)}{a(1-2b)}.$$

Proof. Let us first make a simple observation: If z and w are points in the upper half-plane and $L: \mathbf{R}^2 \rightarrow \mathbf{R}^2$ is the affine map such that $L(0) = 0$, $L(1) = 1$ and $L(z) = w$ (see Figure 2), then the real dilatation of L is given by

$$(2.4) \quad K_L = \frac{|z - \bar{w}| + |z - w|}{|z - \bar{w}| - |z - w|}.$$

To prove the lemma, take the triangulations of A_a and A_b shown in Figure 2 and extend φ affinely to each triangle. After appropriate rescaling, it follows from (2.4) that on a triangle of type I in the figure, the dilatation of φ is comparable to b/a , while on a triangle of type II, the dilatation of φ is comparable to $b(1-2a)/(a(1-2b))$. Since $b(1-2a)/(a(1-2b)) \geq b/a$, we obtain (2.3). \square

Now take a decreasing sequence $\mathbf{d} = \{d_n\}$ of positive numbers with $d_0 = 1$, let $\{a_n\}$ be defined as in (2.1), and consider the Cantor set $\Lambda(\mathbf{d}) = \bigcap \Lambda_n$. Take another such sequence $\mathbf{d}' = \{d'_n\}$ and let $a'_n, \Lambda'_n, \Lambda(\mathbf{d}')$ denote the corresponding data. We construct a homeomorphism $\varphi: \mathbf{C} \rightarrow \mathbf{C}$ which maps the Cantor set $\Lambda = \Lambda(\mathbf{d})$ to $\Lambda' = \Lambda(\mathbf{d}')$. This φ is the uniform limit of a sequence of quasiconformal maps $\varphi_n: \mathbf{C} \rightarrow \mathbf{C}$ with $\varphi_n(\Lambda_n) = \Lambda'_n$, defined inductively as follows. Let φ_0 be the identity map on \mathbf{C} . Suppose φ_{n-1} is constructed for some $n \geq 1$ and

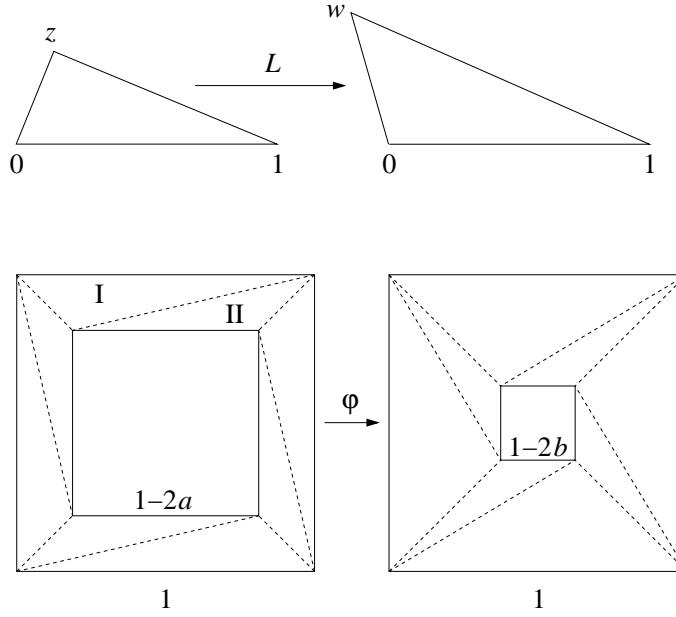

Figure 2.

that it maps each square in Λ_{n-1} affinely to the corresponding square in Λ'_{n-1} . Define $\varphi_n = \varphi_{n-1}$ on $\mathbf{C} \setminus \Lambda_{n-1}$ and let φ_n map each square in Λ_n affinely to the corresponding square in Λ'_n . The remaining set $\Lambda_{n-1} \setminus \Lambda_n$ is the union of 4^n annuli on the boundary of which φ_n can be defined affinely. By rescaling each annulus in $\Lambda_{n-1} \setminus \Lambda_n$ and the corresponding annulus in $\Lambda'_{n-1} \setminus \Lambda'_n$, we are in the situation of Lemma 2.2, so we can extend φ_n in a piecewise affine fashion to each such annulus. This defines φ_n everywhere, and the inductive definition is complete.

To estimate the maximal dilatation of φ_n , note that by the above construction φ_n is conformal in Λ_n and has the same dilatation as φ_{n-1} on $\mathbf{C} \setminus \Lambda_{n-1}$. On each of the 4^n annuli in $\Lambda_{n-1} \setminus \Lambda_n$, the dilatation of φ_n can be estimated using (2.3) in Lemma 2.2. In fact, rescaling each such annulus by a factor $2^n/d_{n-1}$ and the corresponding annulus in $\Lambda'_{n-1} \setminus \Lambda'_n$ by a factor $2^n/d'_{n-1}$, it follows from (2.3) that the dilatation of φ_n on each such annulus is comparable to

$$\begin{aligned} & \max \left\{ \frac{\frac{a'_n}{2^{-n}d'_{n-1}} \left(1 - 2\frac{a_n}{2^{-n}d_{n-1}}\right)}{\frac{a_n}{2^{-n}d_{n-1}} \left(1 - 2\frac{a'_n}{2^{-n}d'_{n-1}}\right)}, \frac{\frac{a_n}{2^{-n}d_{n-1}} \left(1 - 2\frac{a'_n}{2^{-n}d'_{n-1}}\right)}{\frac{a'_n}{2^{-n}d'_{n-1}} \left(1 - 2\frac{a_n}{2^{-n}d_{n-1}}\right)} \right\} \\ &= \max \left\{ \frac{a'_n(d_{n-1} - 2^{n+1}a_n)}{a_n(d'_{n-1} - 2^{n+1}a'_n)}, \frac{a_n(d'_{n-1} - 2^{n+1}a'_n)}{a'_n(d_{n-1} - 2^{n+1}a_n)} \right\} \\ &= \max \left\{ \frac{a'_n d_n}{a_n d'_n}, \frac{a_n d'_n}{a'_n d_n} \right\}. \end{aligned}$$

To sum up, the construction gives a sequence $\{\varphi_n\}$ with the following properties:

- (i) $\varphi_n = \varphi_{n-1}$ on $\mathbf{C} \setminus \Lambda_{n-1}$.
- (ii) φ_n maps each square in Λ_n affinely to the corresponding square in Λ'_n .
- (iii) φ_n is K_n -quasiconformal, where

$$(2.5) \quad K_n \asymp \max \left\{ K_{n-1}, \frac{a'_n d_n}{a_n d'_n}, \frac{a_n d'_n}{a'_n d_n} \right\}$$

and $K_0 = 1$.

Evidently, $\varphi := \lim_{n \rightarrow \infty} \varphi_n$ is a homeomorphism which agrees with φ_n on $\mathbf{C} \setminus \Lambda_n$ for every n and satisfies $\varphi(\Lambda) = \Lambda'$. We call this φ the *standard homeomorphism from Λ to Λ'* . Observe that by the construction, the inverse map φ^{-1} is the standard homeomorphism from Λ' to Λ .

3. Proof of Theorem A

We are now ready to prove Theorem A cited in Section 1.

Proof of Theorem A. If $0 < \alpha, \beta < 2$, it is well known that there is a K -quasiconformal map $\varphi: \mathbf{C} \rightarrow \mathbf{C}$ mapping a set of dimension α to a set of dimension β (see for example [GV]). Moreover, by (1.6), the minimum K this would require is

$$\max \left\{ \frac{\frac{1}{\beta} - \frac{1}{2}}{\frac{1}{\alpha} - \frac{1}{2}}, \frac{\frac{1}{\alpha} - \frac{1}{2}}{\frac{1}{\beta} - \frac{1}{2}} \right\}.$$

In what follows we consider the remaining cases where α and β are distinct and at least one of them is 0 or 2.

Consider the sequences $\mathbf{d} = \{d_n\}$, $\mathbf{d}' = \{d'_n\}$ and $\mathbf{d}'' = \{d''_n\}$ defined by

$$d_n := 2^{-n/\log n}, \quad d'_n := 2^{-\nu n}, \quad d''_n := 2^{-n \log n},$$

where $\nu > 0$, and construct the Cantor sets $\Lambda = \Lambda(\mathbf{d})$, $\Lambda' = \Lambda(\mathbf{d}')$ and $\Lambda'' = \Lambda(\mathbf{d}'')$ as in Section 2. By Lemma 2.1,

$$\dim_H(\Lambda) = 2, \quad \dim_H(\Lambda') = \frac{2}{\nu + 1}, \quad \dim_H(\Lambda'') = 0.$$

We prove that the standard homeomorphisms between these three Cantor sets *and* their inverses are all David maps; this will prove the theorem. In view of Tukia's theorem quoted in Section 1, it suffices to check that the sequence of approximating homeomorphisms are David maps with uniform parameters (C, t, K_0) . In fact, the estimates below show that we can always take $C = t = 1$.

Case 1. Mapping Λ to Λ' . Suppose $\{\varphi_n\}$ is the sequence of quasiconformal maps which approximates the standard homeomorphism φ from Λ to Λ' . To estimate the dilatation of φ_n , note that

$$(3.1) \quad a_n = 2^{-(n+1)}(d_{n-1} - d_n) \asymp 2^{-n}(2^{-(n-1)/\log(n-1)} - 2^{-n/\log n}) \asymp \frac{2^{-n-n/\log n}}{\log n}$$

and

$$(3.2) \quad a'_n = 2^{-(n+1)}(d'_{n-1} - d'_n) \asymp 2^{-n}(2^{-\nu(n-1)} - 2^{-\nu n}) \asymp 2^{-(\nu+1)n}.$$

Hence

$$\frac{a'_n d_n}{a_n d'_n} \asymp \frac{2^{-(\nu+1)n} \cdot 2^{-n/\log n}}{\frac{2^{-n-n/\log n}}{\log n} \cdot 2^{-\nu n}} \asymp \log n.$$

It follows from (2.5) that there is a sequence $1 < K_1 < K_2 < \dots < K_n < \dots$ with $K_n \asymp \log n$ such that φ_n is K_n -quasiconformal. Fix the index n and a number $K > 1$. Choose j so that $K_j \leq K < K_{j+1}$. Then

$$\text{area}\{z : K_{\varphi_n}(z) > K\} \leq \text{area}\{z : K_{\varphi_n}(z) > K_j\} \leq \text{area}(\Lambda_j) = d_j^2 = 4^{-j/\log j}.$$

Since $K \asymp K_j \asymp \log j$, we obtain

$$\text{area}\{z : K_{\varphi_n}(z) > K\} \leq e^{-K},$$

provided that K is bigger than some K_0 independent of n . It follows that the φ_n are all $(1, 1, K_0)$ -David maps.

The inverse maps $\psi_n := \varphi_n^{-1}$ are also K_n -quasiconformal with the same dilatation $K_n \asymp \log n$ and they converge uniformly to $\psi := \varphi^{-1}$. Moreover, if $K_j \leq K < K_{j+1}$, then

$$\begin{aligned} \text{area}\{z : K_{\psi_n}(z) > K\} &\leq \text{area}\{z : K_{\psi_n}(z) > K_j\} \\ &\leq \text{area}(\Lambda'_j) = (d'_j)^2 = 4^{-\nu j} \leq e^{-K}, \end{aligned}$$

provided that K is bigger than some K_0 independent of n . It follows that the ψ_n are all $(1, 1, K_0)$ -David maps.

Case 2. Mapping Λ' to Λ'' . The argument here is quite similar to the previous case. We have

$$(3.3) \quad \begin{aligned} a''_n &= 2^{-(n+1)}(d''_{n-1} - d''_n) \asymp 2^{-n}(2^{-(n-1)\log(n-1)} - 2^{-n\log n}) \\ &\asymp 2^{-n-n\log n+\log n}. \end{aligned}$$

Hence, using (3.2) and (3.3), we obtain

$$\frac{a_n'' d_n'}{a_n' d_n''} \asymp \frac{2^{-n-n \log n + \log n} \cdot 2^{-\nu n}}{2^{-(\nu+1)n} \cdot 2^{-n \log n}} \asymp 2^{\log n}.$$

Let $\{\varphi_n\}$ be the sequence of quasiconformal maps which approximates the standard homeomorphism φ from Λ' to Λ'' . It follows from (2.5) that there is a sequence $1 < K_1 < K_2 < \cdots < K_n < \cdots$ with $K_n \asymp 2^{\log n}$ such that φ_n is K_n -quasiconformal. Fix the index n and a number $K > 1$, and choose j so that $K_j \leq K < K_{j+1}$. Then $K \asymp K_j \asymp 2^{\log j}$ and

$$\begin{aligned} \text{area} \{z : K_{\varphi_n}(z) > K\} &\leq \text{area} \{z : K_{\varphi_n}(z) > K_j\} \\ &\leq \text{area}(\Lambda'_j) = (d'_j)^2 = 4^{-\nu j} \leq e^{-K}, \end{aligned}$$

provided that K is bigger than some K_0 independent of n .

The inverse maps $\psi_n := \varphi_n^{-1}$ are K_n -quasiconformal with $K_n \asymp 2^{\log n}$ and they converge uniformly to $\psi := \varphi^{-1}$. Moreover, if $K_j \leq K < K_{j+1}$, then

$$\begin{aligned} \text{area} \{z : K_{\psi_n}(z) > K\} &\leq \text{area} \{z : K_{\psi_n}(z) > K_j\} \\ &\leq \text{area}(\Lambda''_j) = (d''_j)^2 = 4^{-j \log j} \leq e^{-K}, \end{aligned}$$

provided that K is bigger than some K_0 independent of n .

Case 3. Mapping Λ to Λ'' . Using (3.1) and (3.3), we obtain

$$\frac{a_n'' d_n}{a_n d_n''} \asymp \frac{2^{-n-n \log n + \log n} \cdot 2^{-n/\log n}}{\frac{2^{-n-n/\log n}}{\log n} \cdot 2^{-n \log n}} \asymp 2^{\log n} \log n = n^{\log 2} \log n.$$

Let $\{\varphi_n\}$ be the sequence of quasiconformal maps which approximates the standard homeomorphism φ from Λ to Λ'' . It follows then from (2.5) that there is a sequence $1 < K_1 < K_2 < \cdots < K_n < \cdots$ with $K_n \asymp n^{\log 2} \log n$ such that φ_n is K_n -quasiconformal. Fix n , let K be sufficiently large, and choose j so that $K_j \leq K < K_{j+1}$. Then

$$\text{area} \{z : K_{\varphi_n}(z) > K\} \leq \text{area} \{z : K_{\varphi_n}(z) > K_j\} \leq \text{area}(\Lambda_j) = (d_j)^2 = 4^{-j/\log j}.$$

But $K \asymp K_j \asymp j^{\log 2} \log j$, so

$$\text{area} \{z : K_{\varphi_n}(z) > K\} \leq e^{-K},$$

provided that K is bigger than some K_0 independent of n .

The inverse maps $\psi_n := \varphi_n^{-1}$ are K_n -quasiconformal with $K_n \asymp n^{\log 2} \log n$ and they converge uniformly to $\psi := \varphi^{-1}$. Moreover, if $K_j \leq K < K_{j+1}$, then

$$\begin{aligned} \text{area} \{z : K_{\psi_n}(z) > K\} &\leq \text{area} \{z : K_{\psi_n}(z) > K_j\} \\ &\leq \text{area}(\Lambda''_j) = (d''_j)^2 = 4^{-j \log j} \leq e^{-K}, \end{aligned}$$

provided that K is bigger than some K_0 independent of n . \square

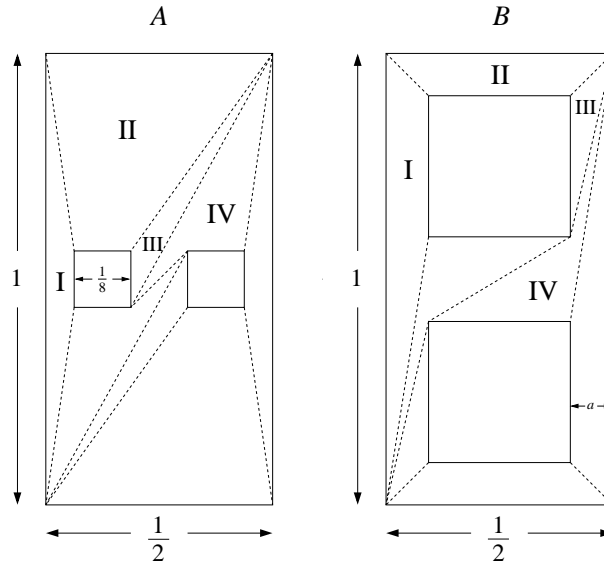

Figure 3. Cell decompositions of A and B .

4. Proof of Theorem B

The idea of the proof of Theorem B is to construct a David map $\varphi: \mathbf{C} \rightarrow \mathbf{C}$ which sends a *linear* Cantor set $\Sigma \subset [-\frac{1}{2}, \frac{1}{2}]$ to a Cantor set of the form $\Lambda(\mathbf{d})$ with dimension 2. The image $\varphi([-\frac{1}{2}, \frac{1}{2}])$ will then be an embedded arc of dimension 2. Since the construction allows $\varphi = \text{id}$ outside the square $[-\frac{1}{2}, \frac{1}{2}] \times [-\frac{1}{2}, \frac{1}{2}]$, we can easily complete this arc to a David circle.

A linear Cantor set. Consider the closed unit square $\Sigma_0 := [-\frac{1}{2}, \frac{1}{2}] \times [-\frac{1}{2}, \frac{1}{2}]$ in the plane. We construct a nested sequence $\{\Sigma_n\}_{n \geq 0}$ of compact sets whose intersection is a linear Cantor set. For $1 \leq j \leq 4$, let $f_j: \mathbf{C} \rightarrow \mathbf{C}$ be the affine contraction defined by

$$f_j(z) = \frac{1}{8}z + \frac{1}{8}(2j - 5),$$

and set

$$\Sigma_n := \bigcup_{j_1, \dots, j_n} f_{j_1} \circ \dots \circ f_{j_n}(\Sigma_0),$$

where the union is taken over all unordered n -tuples j_1, \dots, j_n chosen from $\{1, 2, 3, 4\}$. It is easy to see that Σ_n is the disjoint union of 4^n closed squares of side-length 8^{-n} with centers on $[-\frac{1}{2}, \frac{1}{2}]$ and sides parallel to the coordinate axes (compare Figure 5 left). We define the Cantor set Σ as the intersection $\bigcap_{n=0}^{\infty} \Sigma_n$. Evidently, Σ is a subset of $[-\frac{1}{2}, \frac{1}{2}]$ which has linear measure zero and Hausdorff dimension $\frac{2}{3}$.

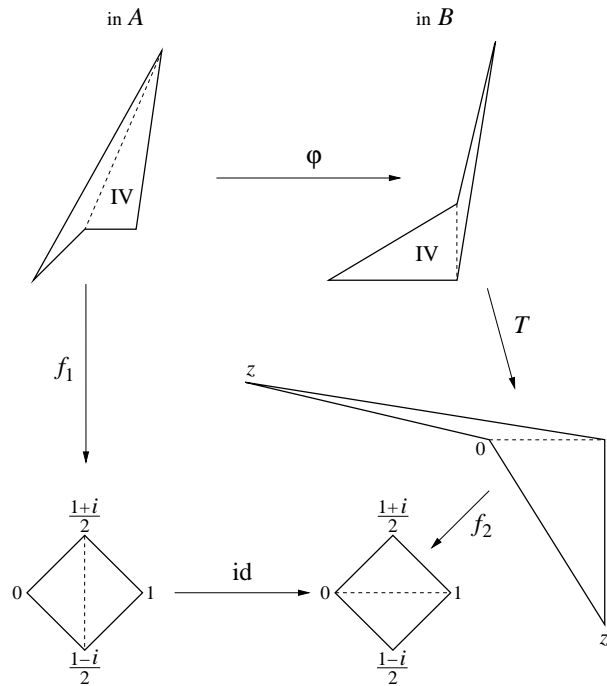

Figure 4. Extending φ between cells of type IV.

A quasiconformal twist. The proof of Theorem B depends on the following lemma which is a triply-connected version of Lemma 2.2. For simplicity we denote by $S(p, r)$ the open square centered at p whose side-length is r .

Lemma 4.1. Fix $0 < a < \frac{1}{5}$ and let A and B be the closed triply-connected sets defined by

$$A := \left([0, \frac{1}{2}] \times [-\frac{1}{2}, \frac{1}{2}] \right) \setminus \left(S\left(\frac{1}{8}, \frac{1}{8}\right) \cup S\left(\frac{3}{8}, \frac{1}{8}\right) \right),$$

$$B := \left([0, \frac{1}{2}] \times [-\frac{1}{2}, \frac{1}{2}] \right) \setminus \left(S\left(\frac{1}{4}(1+i), \frac{1}{2}-2a\right) \cup S\left(\frac{1}{4}(1-i), \frac{1}{2}-2a\right) \right)$$

(see Figure 3). Let $\varphi: \partial A \rightarrow \partial B$ be a homeomorphism which is the identity on the outer boundary component and acts affinely on the inner boundary components, mapping $\partial S(\frac{1}{8}, \frac{1}{8})$ to $\partial S(\frac{1}{4}(1+i), \frac{1}{2}-2a)$ and $\partial S(\frac{3}{8}, \frac{1}{8})$ to $\partial S(\frac{1}{4}(1-i), \frac{1}{2}-2a)$, respecting the horizontal and vertical sides. Then φ can be extended to a K -quasiconformal map $\varphi: A \rightarrow B$, with

$$K \asymp \frac{1}{a}.$$

Proof. We consider the affine cell decompositions of A and B shown in Figure 3 and require φ to map each cell in A to its corresponding cell in B in a piecewise affine fashion. By symmetry, it suffices to define φ piecewise affinely between the cells labelled I, II, III, and IV. We let φ be affine between the triangular

cells III. On the cells I and II we subdivide the trapezoids into two triangular cells and define φ to be affine on each of them. An easy computation based on (2.4) then shows that the dilatation of φ on I, II, and III is comparable to $1/a$.

It remains to define φ between the cells IV and estimate its dilatation. Note that the cell IV in A has bounded geometry, so there is a $K_1 \asymp 1$ and a piecewise affine K_1 -quasiconformal map f_1 from this cell to the square with vertices $0, 1, \frac{1}{2}(1+i), \frac{1}{2}(1-i)$ which maps the horizontal edge of this cell to the segment from $\frac{1}{2}(1-i)$ to 1 (see Figure 4). The cell IV in B , after a conformal change of coordinates T , becomes the 4-gon with vertices

$$0, 1, z := -\frac{1-2a}{4a} + \frac{i}{2}, z' := 1 - \frac{(1-4a)i}{4a}.$$

Let f_2 be the piecewise affine map on this 4-gon which maps the triangle $\Delta(0, 1, z)$ to $\Delta(0, 1, \frac{1}{2}(1+i))$ and the triangle $\Delta(0, 1, z')$ to $\Delta(0, 1, \frac{1}{2}(1-i))$ (see Figure 4). Then a brief calculation based on (2.4) shows that f_2 is K_2 -quasiconformal, with $K_2 \asymp 1/a$. The map φ can then be defined by $T^{-1} \circ f_2^{-1} \circ f_1$, whose dilatation $K_1 K_2$ is clearly comparable to $1/a$. \square

We are now ready to prove Theorem B cited in Section 1.

Proof of Theorem B. Consider the Cantor set $\Sigma = \bigcap_{n=0}^{\infty} \Sigma_n$ constructed above and the Cantor set $\Lambda = \Lambda(\mathbf{d}) = \bigcap_{n=0}^{\infty} \Lambda_n$ constructed in Section 2, where $\mathbf{d} = \{d_n\}$ is defined by $d_n := 2^{-\sqrt{n}}$. It follows from Lemma 2.1 that $\dim_H(\Lambda) = 2$.

We construct a David map $\varphi: \mathbf{C} \rightarrow \mathbf{C}$, identity outside the square $[-\frac{1}{2}, \frac{1}{2}] \times [-\frac{1}{2}, \frac{1}{2}]$, with the property $\varphi(\Sigma) = \Lambda$. Then the embedded arc $\varphi([- \frac{1}{2}, \frac{1}{2}])$ contains Λ and hence has dimension 2. By pre-composing φ with an appropriate quasiconformal map, we obtain a David map sending the round circle to a Jordan curve of dimension 2.

The map φ will be the uniform limit of a sequence of quasiconformal maps $\varphi_n: \mathbf{C} \rightarrow \mathbf{C}$ with $\varphi_n(\Sigma_n) = \Lambda_n$, defined inductively as follows. Let φ_0 be the identity map on \mathbf{C} . To define φ_1 , set $\varphi_1 = \varphi_0$ on $\mathbf{C} \setminus \Sigma_0$ and map each of the four squares in Σ_1 affinely to the “corresponding” square in Λ_1 . Here “corresponding” means that the squares in Σ_0 , from left to right, map respectively to the north west, south west, north east and south east squares in Λ_1 (compare Figure 5). The remaining set $\Sigma_0 \setminus \Sigma_1$ is the union of two triply-connected regions, on the boundary of which φ_1 can be defined affinely, so we can extend φ_1 to each such region as in Lemma 4.1.

In general, suppose φ_{n-1} is constructed for some $n \geq 2$ and that it maps each square in Σ_{n-1} affinely to a square in Λ_{n-1} . Define $\varphi_n = \varphi_{n-1}$ on $\mathbf{C} \setminus \Sigma_{n-1}$ and let φ_n map each square in Σ_n affinely to the “corresponding” square in Λ_n in the above sense. The remaining set $\Sigma_{n-1} \setminus \Sigma_n$ is the union of 2^{2n-1} triply-connected regions on the boundary of which φ_n can be defined affinely. By rescaling each such region in $\Sigma_{n-1} \setminus \Sigma_n$ by a factor 8^{n-1} and the corresponding region in $\Lambda_{n-1} \setminus \Lambda_n$

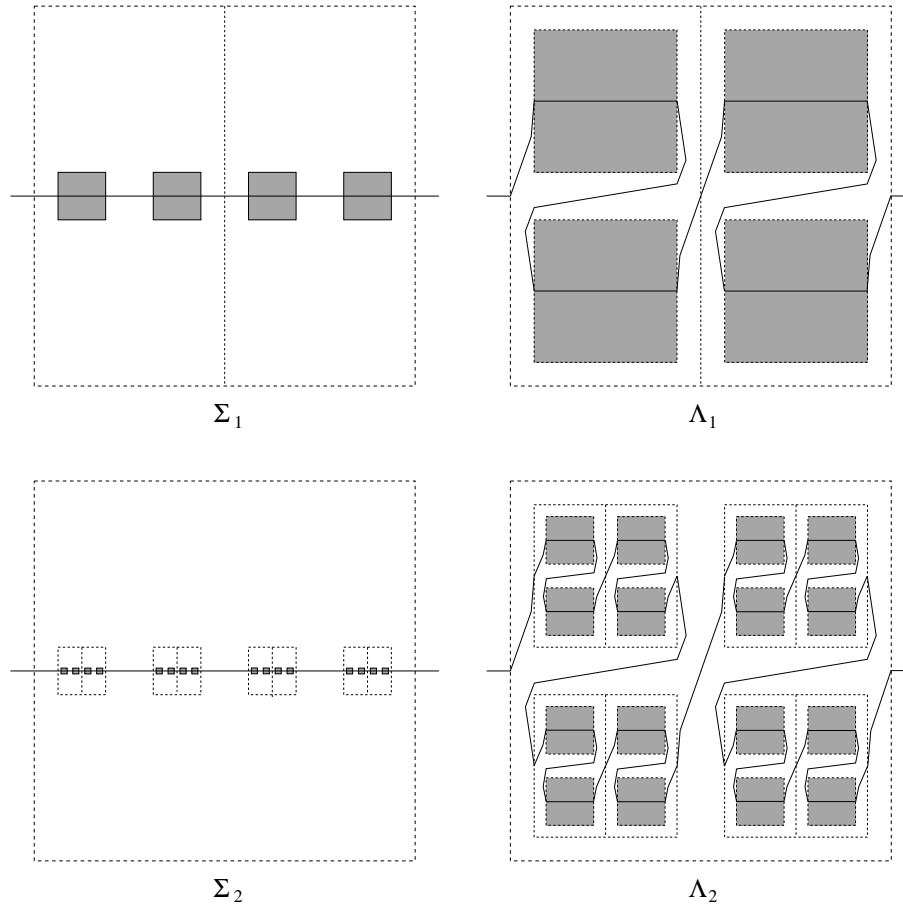

Figure 5. First two steps in the construction of the map φ .
 The solid arcs on the right are $\varphi_n(\mathbf{R})$ for $n = 1, 2$.

by a factor $2^{n-1}/d_{n-1}$, we are in the situation of Lemma 4.1, so we can extend φ_n in a piecewise affine fashion as in that lemma, and the dilatation of the resulting extension will be comparable to

$$\begin{aligned} \frac{d_{n-1}}{2^{n-1}a_n} &= \frac{d_{n-1}}{2^{n-1} \cdot 2^{-(n+1)}(d_{n-1} - d_n)} \\ &= \frac{2^{-\sqrt{n-1}}}{2^{n-1} \cdot 2^{-(n+1)}(2^{-\sqrt{n-1}} - 2^{-\sqrt{n}})} \\ &\asymp \sqrt{n}. \end{aligned}$$

The sequence $\{\varphi_n\}$ obtained this way has the following properties:

- (i) $\varphi_n = \varphi_{n-1}$ on $\mathbf{C} \setminus \Sigma_{n-1}$.
- (ii) φ_n maps each square in Σ_n affinely to the corresponding square in Λ_n .
- (iii) φ_n is K_n -quasiconformal, with $K_n \asymp \sqrt{n}$.

Evidently, $\varphi := \lim_{n \rightarrow \infty} \varphi_n$ is a homeomorphism which agrees with φ_n on $\mathbf{C} \setminus \Sigma_n$ for every n and satisfies $\varphi(\Sigma) = \Lambda$.

To check that φ is a David map, choose a sequence $1 < K_1 < K_2 < \dots < K_n < \dots$ with $K_n \asymp \sqrt{n}$ such that φ_n is K_n -quasiconformal. Fix some n , let $K > 1$, and choose j such that $K_j \leq K < K_{j+1}$. Then

$$\text{area} \{z : K_{\varphi_n}(z) > K\} \leq \text{area} \{z : K_{\varphi_n}(z) > K_j\} \leq \text{area}(\Sigma_j) = 2^{-4j}.$$

Since $K \asymp K_j \asymp \sqrt{j}$, we have

$$\text{area} \{z : K_{\varphi_n}(z) > K\} \leq e^{-K},$$

provided that K is bigger than some K_0 independent of n . It follows that the φ_n are all $(1, 1, K_0)$ -David maps. By Tukia's theorem in Section 1, we conclude that $\varphi = \lim_{n \rightarrow \infty} \varphi_n$ is a David map. \square

Removability of David circles. A compact set $\Gamma \subset \mathbf{C}$ is called (*quasi*)conformally removable if every homeomorphism $\varphi: \mathbf{C} \rightarrow \mathbf{C}$ which is (quasi)conformal off Γ is (quasi)conformal in \mathbf{C} . It is well known that conformal and quasiconformal removability are identical notions.

Every set of σ -finite 1-dimensional Hausdorff measure, such as a rectifiable curve, is removable. Quasiarcs and quasicircles provide examples of removable sets which can have any dimension in the interval $[1, 2)$. One can even construct removable sets of dimension 2: the Cartesian product of two linear Cantor sets with zero length and dimension 1 is such a set.

At the other extreme, sets of positive area are never removable, as can be seen by an easy application of the measurable Riemann mapping theorem. Also, there exist non-removable sets of Hausdorff dimension 1 (see for example [K]).

To add an item to the above list of examples, we show that David circles are removable, which, combined with Theorem B, proves that *there exist removable Jordan curves of Hausdorff dimension 2*. First we need the following simple lemma on David maps (compare [PZ]) whose analogue in the quasiconformal case is standard.

Lemma 4.2. *Suppose $\varphi: \mathbf{C} \rightarrow \mathbf{C}$ is a homeomorphism whose restrictions to \mathbf{D} and $\mathbf{C} \setminus \overline{\mathbf{D}}$ are David. Then φ itself is a David map.*

Proof. The complex dilatation $\mu = \mu_\varphi$ is defined almost everywhere in \mathbf{C} and satisfies an exponential condition of the form (1.4) in \mathbf{D} and in $\mathbf{C} \setminus \overline{\mathbf{D}}$ (by making C bigger and t and ε_0 smaller if necessary, we can assume that the same constants (C, t, ε_0) work for both \mathbf{D} and $\mathbf{C} \setminus \overline{\mathbf{D}}$). So to prove the lemma, we need only show that $\varphi \in W_{\text{loc}}^{1,1}(\mathbf{C})$.

On every compact subset of $\mathbf{C} \setminus \mathbf{S}^1$, the ordinary partial derivatives $\partial\varphi$ and $\bar{\partial}\varphi$ exist almost everywhere, are integrable, and coincide with the distributional

partial derivatives of φ . We check that $\partial\varphi$, and hence $\bar{\partial}\varphi = \mu \cdot \partial\varphi$, is locally integrable near the unit circle \mathbf{S}^1 .

Let D be any small disk centered on \mathbf{S}^1 . We have

$$|\partial\varphi|^2 = \frac{J_\varphi}{1 - |\mu|^2} \leq \frac{J_\varphi}{1 - |\mu|},$$

so that

$$(4.1) \quad |\partial\varphi| \leq (J_\varphi)^{1/2} \cdot (1 - |\mu|)^{-1/2}.$$

Now $J_\varphi \in L^1(D)$ since $\int_D J_\varphi \leq \text{area}(\varphi(D)) < +\infty$, and $(1 - |\mu|)^{-1} \in L^1(D)$ because of the exponential condition (1.4). It follows from Hölder inequality applied to (4.1) that $\partial\varphi \in L^1(D)$. \square

Theorem 4.3. *David circles are (quasi)conformally removable.*

Proof. Let $\varphi: \mathbf{C} \rightarrow \mathbf{C}$ be a David map and $\Gamma = \varphi(\mathbf{S}^1)$. Let $f: \mathbf{C} \rightarrow \mathbf{C}$ be a homeomorphism which is conformal in $\mathbf{C} \setminus \Gamma$. Then the homeomorphism $f \circ \varphi$ is David in \mathbf{D} and in $\mathbf{C} \setminus \bar{\mathbf{D}}$. By Lemma 4.2, $f \circ \varphi: \mathbf{C} \rightarrow \mathbf{C}$ is a David map. Since $\mu_{f \circ \varphi} = \mu_\varphi$ almost everywhere, it follows from the uniqueness part of David's theorem [D] that f must be conformal in \mathbf{C} . \square

References

- [A] AHLFORS, L.: Lectures on Quasiconformal Mappings. - Van Nostrand, 1966.
- [AB] AHLFORS, L., and L. BERS: Riemann mapping's theorem for variable metrics. - Ann. of Math. 72, 1960, 385–404.
- [As] ASTALA, K.: Area distortion of quasiconformal mappings. - Acta Math. 173, 1994, 37–60.
- [BJ] BRAKALOVA, M., and J. JENKINS: On solutions of the Beltrami equation. - J. Anal. Math. 76, 1998, 67–92.
- [D] DAVID, G.: Solutions de l'équation de Beltrami avec $\|\mu\|_\infty = 1$. - Ann. Acad. Sci. Fenn. Ser. A I Math. 13, 1988, 25–70.
- [GV] GEHRING, F. W., and J. VÄISÄLÄ: Hausdorff dimension and quasiconformal mappings. - J. London Math. Soc. 6, 1973, 504–512.
- [GJ] GRACZYK, J., and P. JONES: Dimension of the boundary of quasiconformal Siegel disks. - Invent. Math. 148, 2002, 465–493.
- [K] KAUFMAN, R.: Fourier–Stieltjes coefficients and continuation of functions. - Ann. Acad. Sci. Fenn. Ser. A I Math. 9, 1984, 27–31.
- [LV] LEHTO, O., and K.I. VIRTANEN: Quasiconformal Mappings in the Plane. - Springer-Verlag, 1973.
- [M] MATTILA, P.: Geometry of Sets and Measures in Euclidean Spaces. - Cambridge University Press, 1995.
- [P] PETERSEN, C. L.: Local connectivity of some Julia sets containing a circle with an irrational rotation. - Acta Math. 177, 1996, 163–224.
- [PZ] PETERSEN, C. L., and S. ZAKERI: On the Julia set of a typical quadratic polynomial with a Siegel disk. - Ann. of Math. (to appear).

- [T] TUKIA, P.: Compactness properties of μ -homeomorphisms. - Ann. Acad. Sci. Fenn. Ser. A I Math. 16, 1991, 47–69.

Received 5 March 2003